

**WATER POLLUTION CONTROL
TECHNICAL SPECIFICATION MANUAL**

CITY OF SEYMOUR, INDIANA

**EFFECTIVE JANUARY 10, 2013
(REVISED JANUARY 2015)**



Prepared by:

STRAND ASSOCIATES, INC.®
629 Washington Street
Columbus, IN 47201
www.strand.com

This Water Pollution Control Technical Specification Manual was adopted and approved by the Board of Public Works and Safety of the City of Seymour, Indiana on January 10, 2013, effective immediately. Any future amendments to this manual will require formal approval of the Board of Public Works and Safety prior to becoming effective.

Board of Public Works and Safety

Mayor Craig Luedeman, President
James Rebber
Larry Sunbury

INTRODUCTION

The City of Seymour has prepared this booklet to assist all persons requesting information regarding the Operational Policies and specific sewer and road construction specifications.

The intent of these Construction Standards and Specifications is to provide the minimum requirements for a Contractor or developer who intends to construct municipal facilities that will be connected to or will become a part of the City.

The Seymour Water Pollution Control Facility operates the sewer system under the specific Rules and Regulations of "Chapter 50" of the Municipal Code. Chapter 50 contains the related rules and regulations and user fees which govern the daily operation of the Water Pollution Control Facility. Any person desiring information regarding the policies of the Water Pollution Control Facility should familiarize themselves with the above chapter.

Drawings shall be approved by all appropriate Municipal, State or Federal laws and regulations, and the City prior to starting construction. The City shall be notified when construction will begin and no work shall be concealed or covered until it has been witnessed and approved by a representative from the City.

It shall be understood that only the types of materials or equipment expressly included in these Construction Specifications will be acceptable. Regulations dictated by Federal, State, and Local governing bodies must be obtained from the individual Agencies.

All parts of the Construction Standards and Specifications apply to all phases of work where applicable. In addition, all work shall conform to the Indiana Department of Environmental Management's (IDEM) rules and regulations and the Recommended Standards for Wastewater Facilities (Ten States Standards), latest edition.

Water Pollution Control Facility: Located at 5716 E. County Road 525 N., Seymour, Indiana. Hours from 7:30 a.m. until 3:30 p.m., Monday through Friday, except Holidays. Phone: 522-5351. **For Emergency Sewer Service: During normal working hours: 522-5351, After regular Office hours, page: 523-9654**

Public Works Department: Located at 865 East F Avenue East, Seymour, Indiana. Hours from 8:00 a.m. until 4:30 p.m., Monday through Friday, except Holidays. Phone: 524-1100

Sewer Service Outside of the Seymour Corporate Limits

The Water Pollution Control Facility may accept sewage from approved sources outside the City limits if the drawings are designed and submitted in accordance with Chapter 50 of the Municipal Code, this Technical Specification Manual, and all governmental directions on approval of the Board of Works.

TABLE OF CONTENTS

	<u>Page No.</u>
<u>DEFINITIONS</u>	5
<u>GENERAL APPLICATION PROCEDURES</u>	6
<u>SECTION 1 - Site Clearing and Stripping in Right-of-Way</u>	14
<u>SECTION 2 - Excavation, Fill, Backfill and Grading</u>	16
<u>Figure 2-1: Off Road Trench Detail</u>	
<u>Figure 2-2: Detail for Crossing a Stone Driveway</u>	
<u>Figure 2-3: Detail for Cutting an Asphaltic Street</u>	
<u>Figure 2-4: Detail for Crossing an Asphaltic Driveway</u>	
<u>Figure 2-5: Detail for Crossing a Concrete Driveway</u>	
<u>SECTION 3 - Trenchless Construction</u>	22
<u>Figure 3-1: Typical Boring Casing Pipe</u>	
<u>Figure 3-2: Casing Spacers</u>	
<u>SECTION 4 - Seeding and Sodding</u>	26
<u>SECTION 5 - Hot Mix Asphalt Paving</u>	31
<u>SECTION 6 - Concrete Curb and Gutter, Sidewalks, and Driveways</u>	35
<u>Figure 6-1: New Concrete Drive Section</u>	
<u>SECTION 7 - Cast-in-Place Concrete</u>	40
<u>SECTION 8 - Buried Piping, Manholes and Appurtenances</u>	58
Quick Link to: <u>Sewer Service Branch and Laterals Specifications</u>	66
<u>Figure 8-1: Standard Service Connection</u>	
<u>Figure 8-2: Standard Detail for Typical Precast Manhole with Cone</u>	
<u>Figure 8-3: Flat Top Manhole</u>	
<u>Figure 8-4: Manhole Flowlines</u>	
<u>Figure 8-5: Adjusting Ring Detail</u>	
<u>Figure 8-6: Inside Drop Manhole</u>	
<u>Figure 8-7: Outside Drop Manhole</u>	
<u>Figure 8-8: Service Cleanout</u>	
<u>Figure 8-9: Force Main to Manhole Connection</u>	
<u>Figure 8-10: Testing Marker</u>	
<u>Figure 8-11: Combination Air Release Valve</u>	
<u>Figure 8-12: Sanitary Sewer Laterals</u>	
<u>SECTION 9 - Exposed Piping, Valves and Appurtenances</u>	78

<u>SECTION 10 - Slope Protection and Erosion Control</u>	86
<u>Figure 10-1: Silt Fence</u>	
<u>SECTION 11 - Pumping Stations</u>	91
<u>Figure 11-1: Pumping Station and Valve Pit - Plan View</u>	
<u>Figure 11-2: Pumping Station and Valve Pit - Section View</u>	
<u>Figure 11-3: Typical Pumping Station Electrical Installation</u>	
<u>Figure 11-4: Outdoor Panel Support</u>	
<u>Figure 11-5: Typical Control Panel</u>	
<u>Figure 11-6: Typical Control Panel Wiring Diagram</u>	
<u>Figure 11-7: Typical SCADA RTU Details</u>	
<u>SECTION 12 - Chain Link Fence</u>	102
<u>SECTION 13 - Residential Grinder Pumping Stations</u>	109
<u>Figure 13-1: Residential Grinder Pumping Station</u>	
<u>Figure 13-2: Typical Residential Grinder Pumping Station Plan</u>	
<u>SECTION 14 - Grease Traps</u>	116
<u>Figure 14-1: Typical Grease Trap</u>	
<u>SECTION 15 - As-Built/Record Drawings</u>	120

DEFINITIONS

ASTM - American Society for Testing and Materials

AWWA - American Waterworks Association

DR - Dimension Ratio

HMA - Hot Mix Asphalt

IDEM - Indiana Department of Environmental Management

IDNR - Indiana Department of Natural Resources

INDOT/DOT - Indiana Department of Transportation

NEMA - National Electrical Manufacturers Association

NOI - Notice of Intent

SDR - Standard Dimension Ratio

WPCF - Water Pollution Control Facility

GENERAL APPLICATION PROCEDURES

Applications for sewer service shall be obtained from the Utility office. Completed applications along with drawings, shall be submitted for review and approval in accordance with these rules and regulations. The petitioner is solely responsible for construction and shall turn the completed and accepted sewer over to the Utility for operations and maintenance.

Applications must be submitted at the Utility office and shall be made on a form prepared by the Utility for this purpose and signed by the owner/Contractor desiring sewer service.

Applications will be of two types. The following regulations are separated to treat sewer extensions and individual building sewer tap-ins in different manners as explained in the following procedures.

For sewer extensions, the Applicant will be responsible for all maintenance and repairs of the sewer extension and appurtenances thereto for a period of three years from the date of completion and acceptance of ownership by the Board of Public Works and Safety. As a condition of acceptance of the completed sewer extension, the Applicant shall post with the Board of Public Works and Safety financial guarantees ensuring maintenance of the improvements in good repair. These guarantees shall be in an amount equal to 25% of the estimated cost of the improvements and shall be in effect for a period of three (3) years. The form of the financial guarantees must be acceptable to the City Attorney. All repairs during the three-year maintenance period shall be performed immediately at the expense of the Applicant as ordered by the Board of Public Works and Safety and to the satisfaction of the City.

For sewer extensions, the Applicant shall furnish proof of insurance to the Board of Public Works and Safety naming the City as additional insured in the following amounts before construction begins:

Bodily Injury Liability	\$1,000,000
Property Damage Liability	\$1,000,000

GENERAL CONSTRUCTION REQUIREMENTS

The applicant must obtain all permits required by Federal, State, County and City ordinances, rules, and regulations.

The Utility does not ensure that the sewer information shown on drawings of record is correct. The Contractor is cautioned to verify the actual location of sewer mains in the field. The Utility will not be liable for additional costs incurred in determining actual location/elevation.

Construction must comply with all applicable Federal, State, County and City ordinances, rules, and regulations in making connection as to cutting street pavements, excavating in a public street or highway, making connection to sewer and replacing street or highway pavements.

The applicant will be responsible for all costs of construction, liability and inspection on the project up to the time the connection pipe is in place and the sewer accepted by the City.

The City must be informed two (2) working days before any sewer construction is initiated, one (1) working day for lateral tap-ins, (unless there is an emergency) to arrange for an inspector to

be on the site for periodic inspections during construction progress. The City must be given adequate notice on restarts, after interruption of work.

All sewers must be inspected by the City, as they are being constructed. The Contractor must coordinate cover-up and backfill with such inspection. If sewer construction has been initiated and covered-up before informing the City, a dig up and start over could be required if the City requires it.

The Water Pollution Control Authority or Building Commissioner's office will have the right, when presenting proper identification, to enter upon the site/property for inspection of the sewer construction, and may halt the construction at any time the work is not in compliance with the approved drawings and specifications and until corrections have been made. No clear-water drainage systems shall be connected to or constructed such that they flow into a sanitary sewer system - including parking lots, athletic fields, etc. All underground seepage picked up by sump pumps and/or perimeter drains, etc., and cooling water discharges must be directed to the storm drainage.

The sanitary sewer is for sanitary use only and nothing is to be discharged into it that would interfere with any part of the sewer system or treatment process facility.

PAYMENT FOR SEWER SERVICES

The user is to pay for sewer and waste disposal services at rates as established by Appendix B of Chapter 50 of the Municipal Code.

PRE-TREATMENT PROVISIONS

Commercial, industrial, institutional operations, etc. must notify the Pre-Treatment Coordinator of their intentions to discharge wastewater into the City's collection system at least ninety (90) days prior to commencing such discharge. The Pre-Treatment Coordinator will determine whether a Wastewater Discharge Permit is required. The prospective user may be required to supply information projecting the quality and quantity of water to be discharged. All services requiring an Industrial Wastewater Permit will be required to install a permanent inspection and sampling manhole. For further information regarding pre-treatment provisions or inspection manholes, refer to Chapter 50 of the Municipal Code, or contact the Pre-Treatment Coordinator who is located at 5716 East County Road 525 North, and may be reached by phone at 522-5351.

SEWER MAIN EXTENSION

Procedural Steps

Following is a brief outline of the procedural steps that must be followed to install a sanitary sewer within the service area of the City. The applicant is cautioned to read the more detailed descriptions of each of these steps that appear later in this Technical Specification Manual. The Impact Board meets the second and fourth Thursdays of the month prior to the Board of Public Works and Safety meeting. Emergencies will be handle on a case-by-case basis.

1. Applicant/User submits application and three copies of the preliminary drawings and specifications to the Building Commissioner's office along with applicable deposit/fees to the Clerk Treasurer's office.

2. The Building Commissioner reviews the preliminary drawings and specifications and distributes copies to applicable members of the Impact Board.
3. Impact Board members review preliminary drawings and specifications and provide comments back to the Building Commissioner's office.
4. Building Commissioner compiles comments from Impact Board and sends letter to Applicant/User.
5. Applicant/User revises drawings and specifications and submits final copies to Building Commissioner.
6. Upon approval of Building Commissioner and Impact Board, final drawings and specifications are forwarded to the Seymour Board of Public Works and Safety for approval.
7. Seymour Board of Public Works and Safety approves final drawings.
8. Applicant/User can construct sewer system.
9. Applicant/User tests sewer system with Water Pollution Control Authority present.
10. Applicant/User requests inspection of sewer system by Water Pollution Control Authority.
11. When punch list items are complete, applicant/user requests sewer system final inspection.
12. Upon completion of a satisfactory final inspection, the Applicant's/User's engineer requests acceptance of ownership of the improvements by the City through the Seymour Board of Public Works and Safety and submits the requisite financial guarantees to be in effect for a period of three years after acceptance of ownership by the City.
13. Seymour Board of Public Works and Safety accepts/declines sewer system.

Service Areas

Sewer systems that **qualify** for acceptance must have the following service areas:

- a. Single family residential subdivisions (multiple lots with more than one owner)
- b. Commercial and industrial subdivisions (multiple lots with more than one owner)

Sewer systems that **do not qualify** for acceptance, unless the sewers are built along the perimeter of the property or such that they are designed to serve adjacent property and provide access for maintenance and future extensions, include the following:

- a. Apartment Complex sewer systems
- b. Mobile Home Park sewer systems
- c. Shopping Center sewer systems

NOTE: Although these sewer systems do not qualify for acceptance, they must be built to comply with the rules, regulations and specifications outlined in this booklet.

Sewer Main Extension Application

Drawings submitted with any application for sewer extensions must be complete, including material specifications, estimated flow, elevations, easements, safety devices, and necessary pumping equipment. The drawings must be signed by a professional engineer licensed in the

State of Indiana or a Land Surveyor if the sewer is to be a gravity-only type of installation. Drawings and subsequent construction must meet all Federal, State, County and local standards, rules and regulations. Each application must be submitted with a separate application fee.

The preliminary drawings shall consist of plan and profile drawings showing the proposed sewer layout with right-of-ways, easements, locations of other utilities, and flow calculations for immediate service area and future tributary service areas. **Applicant/User is responsible for determining and submitting flow calculations showing the impacts, for both immediate and future flows, to the downstream portions of the sewer system including all downstream pumping stations and piping systems. Applicant/User is responsible for all costs required to upgrade the existing sewer system that are needed to accommodate the Applicant's/User's immediate and future flows. It is the intent of the City to minimize the number of pumping stations. Therefore, the Applicant/User is required to evaluate and report on the feasibility of extending existing gravity sewers to the area proposed to be served. The report shall be included with the application.**

Any special construction peculiarities required should be explained in a letter attached to the drawings.

No drawings shall be presented to the Building Commissioner, Impact Board or the Seymour Board of Public Works and Safety if such drawings include the use of sewers previously installed which have not been accepted by the City.

The application, drawings, specifications and supporting data will be forwarded to the Impact Board members. A comprehensive plan, including pumping station requirements and long-term service for future tributaries in the area, shall be developed based upon accepted formulas for waste generation, pipe sizes and so forth. If pumping station drawings are required, they will be presented to the Water Pollution Control Authority for its review. The Water Pollution Control Authority then will prepare a letter noting any and all recommended changes in the drawings. The Building Commissioner will forward them to the applicant's engineer to be incorporated into the drawings. A capacity letter, including any requested changes, will be forwarded to IDEM.

Under normal conditions the Water Pollution Control Authority will complete their investigation within thirty (30) days. The Water Pollution Control Authority shall have the right to modify the proposed extension to increase capacity or service areas beyond the development or land owned or controlled by the Applicant/User and shall participate in the cost of such modifications as approved by the Seymour Board of Public Works and Safety. If the agreed amount is **under** fifty thousand dollars (\$50,000.00), it will be paid to the applicant/user upon completion of the sewer and acceptance for maintenance by the City.

If the agreed amount is **over** fifty thousand dollars (\$50,000.00), the amount will be paid as follows:

- Twenty-five percent (25%) upon start of construction
- Twenty-five percent (25%) when project is fifty percent (50%) complete (based on City's judgment)
- Fifty percent (50%) balance when the sewer is accepted for operation.

NOTE: The City requires that the amount paid the applicant/petitioner at start-up of construction be reflected in the letter of credit or bonding by the Area Plan Commission. When

revised drawings have been received from the applicant's engineer and approved by the Impact Board, the drawings will be presented to the Seymour Board of Public Works and Safety for their approval in a regular meeting. The Board's secretary shall inform the applicant/petitioner in writing of the decision of the Board and shall enclose a copy of the application signed by the Board President or designee.

Should the applicant's engineer disagree with the suggested recommendations, a written request to the Board of Public Works and Safety for a review and reconsideration can be made. The Board will make the final decision at a regular meeting and inform the applicant's engineer in writing of its decision.

Construction Procedures/Sewer Extension

Each property being serviced by new sewer services shall provide separate lines for storm and sanitary flows. Sanitary sewer laterals shall have clean-outs and backwater valves and shall be no less than six (6) inches in diameter between the clean-out and main line. When extending mains, lateral stubs shall be installed to known future points of service. Such lateral stubs shall terminate five feet beyond the sewer easement and/or right-of-way line onto the property being served. Laterals shall not terminate under a roadway, sidewalk, or drive.

The sewer construction should be started within one hundred-eighty (180) days from approval by the Board of Public Works and Safety and completed within three hundred-sixty-five (365) calendar days from the date of Board approval of the drawings. If not completed or granted an extension of time within the specified time period, the application will expire and a new application and service fee will be required to reactivate the project (per the Building Commissioner).

An extension of time may be granted in reply to a written request to the Board, when request is reviewed and found to be justified.

Construction of any extension of the sewer system shall be done only by a Contractor having a current Bond and Certificate of Insurance on file with the City.

NOTES:

Additional sewer construction information can be found in Chapter 50 of the Municipal Code.

Additional street and sidewalk information can be found in Chapter 94 of the Municipal Code.

For detailed construction specifications for sewer main extensions and related appurtenances, refer to the Specifications and Figures found in this Technical Specification Manual and/or contact the WPCF.

Final Inspection / Sewer Extension

Upon completion of the installation, a request for inspection of the sewer system by the Water Pollution Control Authority should be made by the applicant/petitioner in a letter to the Water Pollution Control Authority, and must include copies of the certified air and mandrel test results.

A punch list will be compiled by the Water Pollution Control Authority and forwarded to the applicant/petitioner's engineer. No further action will be taken until sewer construction conforms to the corrections required by the punch list and the Water Pollution Control Authority has been

informed in writing that another inspection is requested. The Water Pollution Control Authority will make the inspection within ten (10) working days upon receipt of request.

Failure to meet punch list requirements within ninety (90) days may result in disconnection of the sewer service involved. In instances where a letter of credit/bond has been given to the Area Plan Commission, such financial tools may be used to assure proper completion of the project.

Requests to the City for qualifying sewers as operational after passing final inspection must be made in writing to the Water Pollution Control Authority and the Board of Public Works and Safety. Two complete sets of approved as-built/record drawings and easements, etc. must be submitted along with the request. One electronic copy of the as-built/record drawings in Portable Document Format (pdf) shall also be submitted on CD.

The applicant shall certify in a letter to the Board of Public Works and Safety (submitted through the Water Pollution Control Authority) that the sewer system has been completed according to the approved drawings and specifications and shall state that the applicant warrants the system free from structural failures as results of faulty workmanship or materials for three (3) years. Upon acceptance by the Board of Public Works and Safety, the sewer will become property of the City subject to the three (3) year maintenance period during which the Applicant is responsible for maintenance and repairs. Thereafter the sewer system will be maintained by the Water Pollution Control Authority.

SEWER CONNECTION / TAP IN

Applicant Procedures/Tap-In

All free-standing structures dedicated for individual activity (use) for commercial, industrial or institutional enterprise will require individual sewer service and a dedicated tap-in connection. This includes every structure, although individual buildings may be connected by a passageway, walk-way, tunnel, and so-forth.

All buildings being re-modeled, except those designated for single family residential use, must be reviewed for possible additional tap fees. A separate application is required for each building.

In Combined Sewer Areas, any alterations of property use must be reviewed to verify that no additional storm water will be discharged into the combined sewer. A separate application is required for each such instance.

Storm water drainage and detention must meet the criteria as set by the City's Municipal Separate Storm Sewer System Program.

Application for sewer service to an individual building, domestic, commercial or industrial, shall be processed after payment of tap fee and application fee. The application then will be forwarded to the Water Pollution Control Authority for its records.

Any proposed installation utilizing lines not previously accepted for maintenance by the utility may be rejected.

Before any construction is initiated on a lot/site, after getting the tap-in connection application approved, a curb/street cut permit must be obtained from the Clerk Treasurer's Office. This will require evidence of an approved Tap-In/Connection Application from the Board of Public Works and Safety. A copy will be forwarded to the Water Pollution Control Authority for review and a copy must be presented to the Building Commission Office. **Please note: liability insurance and/or a bond may be required for the curb/street cut permit, see Chapter 94 of the Municipal Code for additional information.**

Construction Procedures/Tap-In

No sewer from a residence or commercial building shall be tapped or connected to the sewer system without inspection of the connection by the Water Pollution Control Authority or a Designated Representative. The Contractor must coordinate cover-up and back fill with such inspection. If the sewer construction has been initiated and covered-up, before informing the Water Pollution Control Authority or Designated Representative, a dig up and start over could be required if the Water Pollution Control Authority or the Building Commission require it. A request for inspection shall be made at least one (1) working day prior to making such connection.

Any expense for after-hours inspections shall be paid by the Contractor or applicant requiring the special inspection.

The building sewer and tap-in or connection shall be done by or under the direction of a sewer contractor or plumber.

The entry into the main must be made for a good fit of the Wye Fitting, using an approved fitting that will not slip through the entry and obstruct the sewage flow.

If the main is damaged, it must be repaired in an approved manner acceptable to the Water Pollution Control Authority.

When a tap is to be made at a location requiring construction from the main to the building being served, it must be laid at one time, and will be inspected by the Water Pollution Control Authority. Construction must include the Wye Fitting (if required).

No lateral shall be constructed across the private property of others unless specifically approved and with the proper legal easement agreements.

No tap-ins to laterals will be permitted, except for appurtenant structures associated with a private residence to be used as a guest house, private library, garage, etc. These can be tapped into the main structure lateral.

No building may have plumbing located from the basement or below first floor level, connected for gravity flow, without positive assurance of adequate gravity flow to the main. Sewage ejectors or pumps with shut-off and backflow valves may be required to direct, control and maintain the proper discharge and prevent backflow through the sewer.

If a tap-in lateral has been abandoned, a new application is required for approval to re-connect. Abandoned or separated laterals are to be plugged at the property line. Property abandoned over five (5) years will be treated as if no previous improvements had ever been made.

Final Inspection/Tap-In

When the applicant considers the sewer is ready for use, a final inspection must be requested of the Water Pollution Control Authority. The Water Pollution Control Authority or Building Commission inspector will inform the plumber or his representative in writing when the sewer has been approved.

The sewer can be put into service upon final inspection and approval from the Building Commissioner with a certificate of occupancy.

Waivers/Alternatives

A waiver or alternative to the technical specifications required by this manual may be approved by the City on a case-by-case basis. The waiver/alternative must be submitted, in writing, along with the application to the Building Commissioner's office.

Easements

No fence, wall, or other permanent structure shall cross a public or private easement. Any fence, wall, or other permanent structure that encroaches upon a City easement may be removed by the City at the Owner's expense.

NOTES:

For detailed construction specifications for tap-ins and related appurtenances, refer to the Specifications and Figures in the rear of this booklet.

No sewer conveying wastewater shall be less than 8 inches in diameter.

All sewers shall be designed and constructed to give mean velocities, when flowing full, of not less than 2.0 feet per second, based on Manning's formula using an "n" value of 0.013. The following are the recommended minimum slopes which should be provided; however, slopes greater than these are desirable.

Sewer Size (inches)	Minimum Slope in Feet per 100 Feet
8	0.40
10	0.28
12	0.22
14	0.17
15	0.15
16	0.14
18	0.12
21	0.10
24	0.08
27	0.067
30	0.058
33	0.052
36	0.046
39	0.041
42	0.037

SECTION 1

SITE CLEARING AND STRIPPING IN RIGHT-OF-WAY

PART 1–GENERAL

1.01 SUMMARY

- A. Work Included:
 - 1. Permits
 - 2. Removal of surface debris.
 - 3. Removal of paving, curbs, and sidewalks.
 - 4. Removal of trees, shrubs, and other plant life.
 - 5. Strip, stockpile, and replace topsoil.

1.02 PERMITS

- A. Contractor shall obtain a permit from the City (Clerk Treasurer’s office) prior to performing any work that disturbs the surface of any public easement or other public right-of-way.
- B. Contractor shall obtain all other permits required to perform work in the right-of-way prior to construction. Other permits include, but are not limited to, erosion control permit including IDEM Notice of Intent, IDNR permits, Corps permits, and County Highway and INDOT permits.

PART 2–PRODUCTS

NOT APPLICABLE

PART 3–EXECUTION

3.01 PREPARATION

- A. Contractor shall identify existing plant life to remain and shall tag accordingly.

3.02 PROTECTION

- A. Contractor shall protect from damaging all utilities and structures that are to remain.
- B. Contractor shall protect trees, plant growth, and features designated to remain as final landscaping.

3.03 CLEARING AND GRUBBING

- A. Clearing and grubbing shall consist of cutting and disposing of trees, brush, windfalls, logs, and other vegetation, and the removing and disposing of roots,

stumps, stubs, grubs, logs, and other timber from within the clearing limits, or fall within the excavation, embankment, or improved areas of the site.

- B. All roots and stumps shall be removed to a depth of not less than 12 inches below the original ground surface in embankment areas. In cut areas, such material shall be removed to a depth of not less than 12 inches below the subgrade.

3.04 REMOVALS

- A. Contractor shall remove from the site all trees, brush, and other vegetation, debris, and rocks that fall within the excavation and grading limits, as well as any paving, curb and gutter, and sidewalks that are to be removed.

3.05 STRIPPING

- A. Excavate topsoil from areas to be built upon, cut or filled, or to have surface improvements, including roadways and walks.
- B. Stockpile topsoil on site and protect from erosion.
- C. Contractor shall replace topsoil on top of excavation and provide additional topsoil as required.

END OF SECTION

SECTION 2

EXCAVATION, FILL, BACKFILL, AND GRADING

PART 1-GENERAL

1.01 SUMMARY

- A. Work Included: Excavating, filling, backfilling, and grading for this work includes, but is not necessarily limited to:
 - 1. Excavating for footings, foundations, roads, and utilities.
 - 2. Placing and compacting all fill and backfill.
 - 3. Placement of granular mat vapor barrier and granular cushion below interior slabs on grade.
 - 4. Placement of crushed stone mat below tank slabs and manhole/vault slabs, or other structures where required.
 - 5. Rough and finish grading prior to paving, seeding, etc.
- B. All sewer main pipe shall be backfilled the same day installed. In future street areas, the excavated material shall be mechanically compacted or water jetted when the soil conditions warrant or fill material meeting INDOT Specifications may be placed and compacted. Care should be used to avoid unbedding the pipe when backfilling.

1.02 REFERENCES

- A. ASTM D1557–Test Methods for Moisture Density Relations of Soils and Soil–Aggregate Mixtures using 10-pound Rammer and 18-inch drop.
- B. Standard Specifications: Unless otherwise indicated, Standard Specifications within this Section shall refer to the State of INDOT, Standard Specifications, Latest Edition, including all issued Supplemental Specifications.

PART 2-PRODUCTS

2.01 COMPACTED FILL

- A. All fill and backfill material designated to be compacted fill shall be granular with no stones larger than 4 inches and shall be reasonably well graded throughout the particle size range. Of that portion of the material passing the No. 4 sieve, not more than 25% shall pass the No. 200 sieve, and material shall have less than 5% clay content. When placing fill during wet weather or in wet areas, this requirement shall be modified to not more than 5% passing the No. 200 sieve. Adequately dewatered areas are not defined as wet areas.
- B. Native material may be used as compacted fill if it meets the above Specification. Contractor shall determine whether native material meets the above Specification.

2.02 GRANULAR CUSHION

- A. Granular cushion beneath floor slabs-on-grade shall meet requirements of Size No. 53 of Section 904.

2.03 EMBANKMENT FILL

- A. Embankment fill shall contain no stumps, brush, rubbish, or other perishable material. The top 12 inches of the earth embankment shall be earthy material free from large stones.

2.04 CONCRETE FILL

- A. All cement used shall be Portland Cement and shall conform to ASTM C150 and shall be Type I or Type III. All cement shall be the product of one reputable manufacturer and mill.

2.05 CLAY FILL

- A. Clay fill shall contain at least 25% clay minerals (material finer than 0.002 mm).

2.06 FLOWABLE FILL

- A. Flowable fill shall be a self-compacting, self-leveling, material consisting of a mixture of fine aggregate and filler (as needed), water, and cementitious materials (Portland cement, fly ash, granulated blast furnace slag) that is in a flowable state at the time of placement meeting the requirements of the National Ready Mixed Concrete Association Guide Specification for Controlled Low Strength Materials. The flowable fill shall be proportioned by the ready mixed concrete supplier on the basis of field experience and/or laboratory trial mixtures to produce a cohesive and non-segregating mixture.

PART 3-EXECUTION

3.01 PROTECTION

- A. Contractor will be held liable for any damage that may result to City property from excavation or construction operations.

3.02 UTILITIES

- A. Before starting excavations, Contractor shall locate existing underground utilities in all areas of the work.
- B. If utilities are to remain in place, Contractor shall provide adequate means of protection during earthwork operations.
- C. Should uncharted or incorrectly charted piping or other utilities be encountered during excavation, consult utility owner immediately for directions.

- D. Cooperate with City and utility companies in keeping respective services and facilities in operation, and repair any damaged utilities to satisfaction of utility owner.
- E. Contractor shall not interrupt existing utilities serving facilities occupied and used by the City or others except when permitted in writing by the City.

3.03 FINISH ELEVATIONS AND LINES

- A. Contractor is responsible for setting and establishing finish elevations and lines.

3.04 EXCAVATION

- A. All excavated material that does not meet the specification for compacted fill or embankment fill or meets the specification but is not required for backfill or fill shall be classified as excess material and shall be removed from the right-of-way and disposed of.
- B. Excavations scheduled to extend below groundwater shall not be started until the area has been dewatered.

3.05 BACKFILLING TRENCHES

- A. All trenches shall be backfilled from the bottom of the trench to a depth of one foot above the top of the pipe with compacted No. 8 aggregate material placed in layers of three inches and compacted by tamping. Backfilling material shall be deposited in the trench for its full width on each side of the pipe, fittings, and appurtenances simultaneously. The Contractor shall place the backfill around the pipe in such a manner as to confirm there are no void spaces.
- B. From the centerline of the pipe, fittings and appurtenances to a depth of one foot above the top of the pipe, Contractor shall use special care in placing this portion of the backfill so as to avoid damaging or moving the pipe.
- C. When the trench crosses a driveway or other access, the Contractor shall backfill the trench immediately to restore access. Contractor shall check all such areas every day to see if any settlement has occurred and, if so, shall backfill again to maintain a smooth surface.
- D. All driveways, entrances, and parking areas, consisting of crushed stone, gravel, concrete, or asphaltic surfaces, including those in public rights-of-way, damaged by the construction shall be repaired and replaced with like material to the original grade. All damaged curbs and sidewalks shall also be replaced with like material to the original grade.
- E. All areas disturbed by construction shall be restored to at least the original preconstruction conditions, and to the satisfaction of the City or its authorized representative.

- F. One year from completion of the project the Contractor shall return to the site and backfill or smooth out any settlement that has occurred in the entire length of the pipeline. Any areas repaired shall be seeded and fertilized.

3.07 PREPARATION OF SUBGRADE

- A. After the site has been cleared, stripped, and excavated to subgrade, thoroughly compact subgrade to the requirements specified for compacted fill below. If required by the City, scarify and moisture condition the subgrade.
- B. Remove all ruts, hummocks, and other uneven surfaces by surface grading prior to placement of fill.
- C. All slab-on-grade and road subgrades shall be proof rolled with a heavy rubber-tired construction vehicle (such as a fully loaded tandem-axle dump truck). If required by the City, proof rolling shall be conducted in the presence of a Project Soils Engineer (Geotechnical Engineer).

3.08 COMPACTED FILL AND BACKFILL

- A. All fill and backfill, except as otherwise specified, shall be compacted fill placed to within 4 inches of the bottom of the topsoil or to the bottom of the structure or other improvement.
- B. Unless otherwise noted, structures with a top slab shall not be backfilled until the slab is in place and has reached its specified 28-day strength.
- C. In fill areas above existing grade around structures, compacted fill shall be placed within a minimum of 10 feet from the structure.
- D. No fill shall be placed under water or over unsuitable subgrade conditions.
- E. All fill and backfill, except embankment fill and clay fill, shall be compacted as follows:
 - 1. Class 1 Compaction: This class of compaction shall apply to all fill areas under buildings, structures, piping, roadway and parking areas, curb and gutter, and backfill within ten feet of structure walls. All compacted material shall be placed in uniform layers not exceeding 8 inches in loose thickness prior to compaction, unless otherwise specified. Each layer shall be uniformly compacted to a dry density at least 95% of the maximum dry density as determined by a laboratory compaction test at the optimum moisture content (ASTM Test Designation D1557). Compaction shall be obtained by compaction equipment appropriate for the conditions.
 - 2. Class 2 Compaction: This class of compaction shall be used in excavated areas beyond 10 feet of structures without any piping or adjacent foundations. The material shall be deposited, spread, and leveled in layers generally not exceeding 12 inches in thickness before compaction. Each layer of the fill shall be compacted to at least 90% of the maximum

dry density (testing same as Class 1). Compaction shall be obtained by compaction equipment appropriate for the conditions.

- F. No frozen material shall be placed nor shall any material be placed on frozen ground.
- G. Four inches of clay fill or native topsoil shall be placed and compacted to at least a firm consistency in areas to be seeded or sodded prior to placement of topsoil.

3.09 EMBANKMENT FILL

- A. Embankment fill may be placed in fill areas to be seeded or sodded if no piping exists in the fill and the areas are at least 10 feet from any structure.
- B. Embankment fill shall be deposited, spread, and leveled in layers generally not exceeding 12 inches in thickness before compaction. Each layer shall be compacted to the degree that no further appreciable consolidation is evidenced under the action of the compaction equipment. The required compaction shall be obtained for each layer before any material for a succeeding layer is placed thereon. Compaction shall be obtained using the hauling and leveling equipment, and in addition, tamping rollers, pneumatic-tired rollers, vibratory rollers, or other types of equipment required to produce the desired results.

3.10 CONCRETE FILL

- A. In areas where there is inadequate room for compaction equipment and in other areas as shown or specified, Type I or Type III concrete or flowable fill shall be used as fill material. See sections 2.04 and 2.06.

3.11 GRADING

- A. Contractor shall perform all rough and finish grading required.

3.12 PLACING GRANULAR CUSHION AND VAPOR BARRIER

- A. When subgrade is prepared for slab-on-grade areas, Contractor shall place the vapor barrier.
- B. A 6-inch layer of granular cushion shall then be placed, compacted, and finish graded.

3.13 PLACING CRUSHED STONE AND GEOTEXTILE FABRIC

- A. The same day that the subgrade is exposed, place geotextile fabric on subgrade, and place 12 inches of crushed stone mat below tank slabs, manholes, vault slabs, and basement floors. Compact in place.

3.14 COMPACTION TESTING

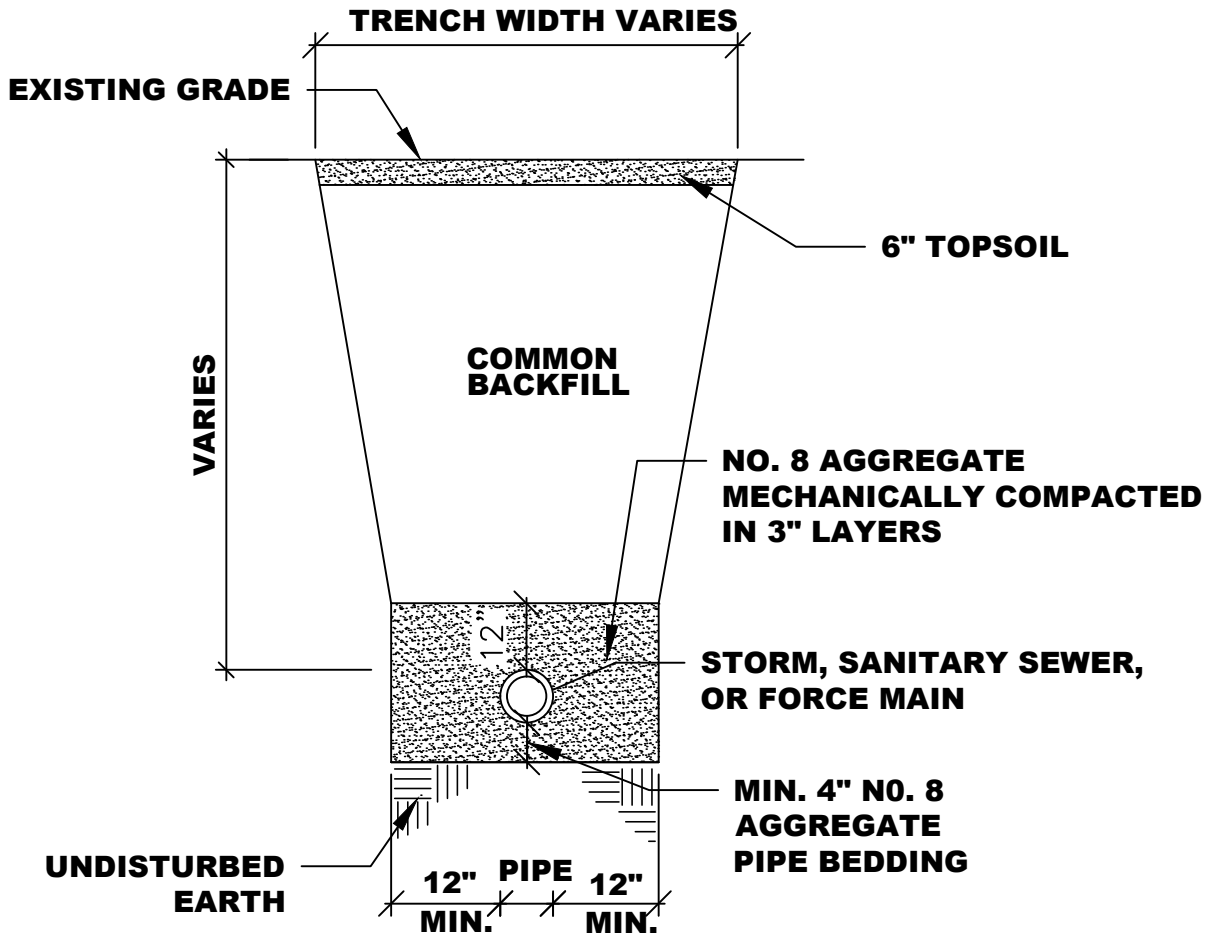
- A. If required by the City, compaction tests shall be done by a Project Soils Engineer. Location and frequency of the tests shall be as recommended by the Project Soils Engineer .

3.15 EXCAVATED SOLID WASTE FILL MATERIALS TO BE LANDFILLED

- A. If any solid waste fill materials are encountered, in City right-of-way, they shall be excavated and removed to a licensed sanitary landfill. Solid waste fill material is defined as any debris, refuse, glass, ash, or other material not native to the site but having been placed on site during past filling operations and mixed with soil.

END OF SECTION

File: S:\COL\4100--4199\4122\067\Acad\Storm Sewer\Crossings.dwg Time: Feb 04, 2014 - 9:44am



**OFF ROAD
TRENCH DETAIL**

NO SCALE

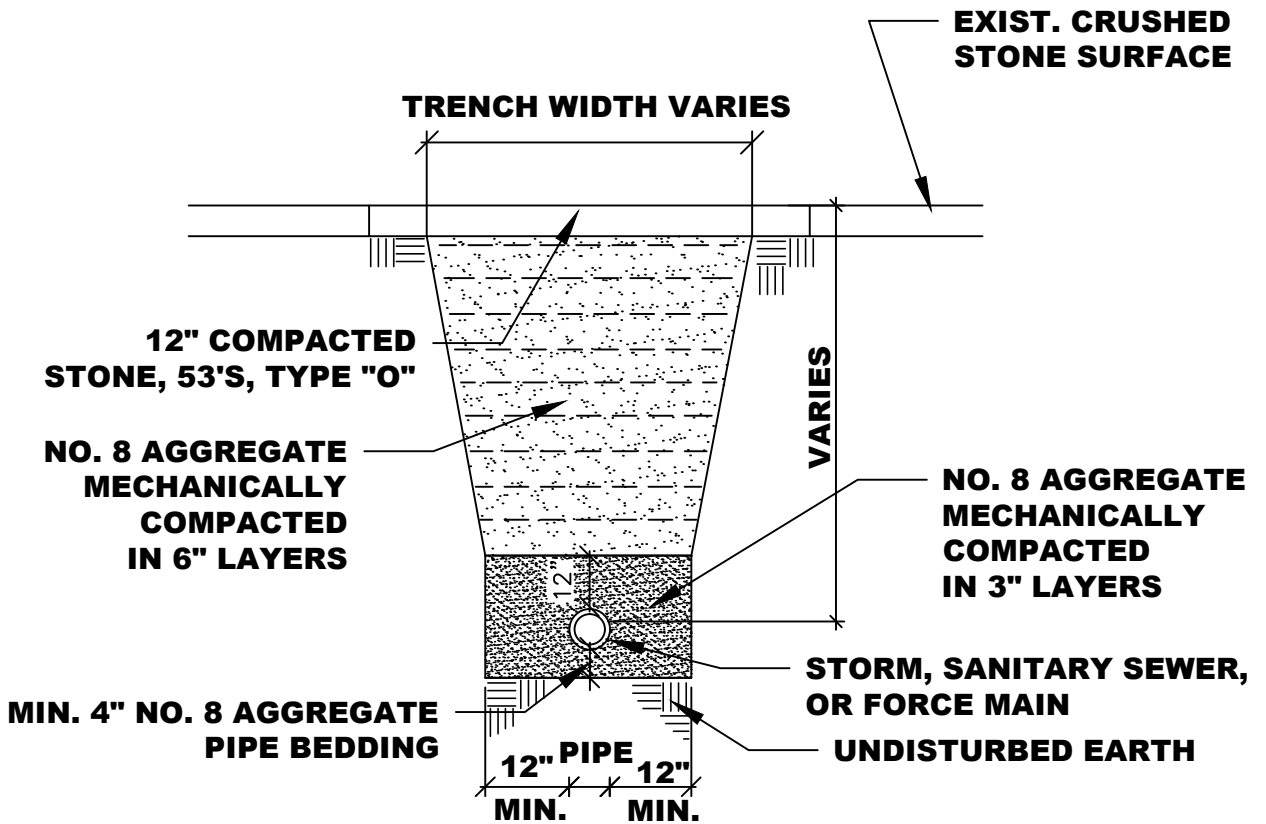
**SECTION 2
EXCAVATION, FILL, BACKFILL, AND GRADING
STANDARD CONSTRUCTION SPECIFICATIONS
OFF ROAD TRENCH DETAIL
CITY OF SEYMOUR
SEYMOUR, INDIANA**



FIGURE 2-1

4122.067

File: S:\COL\4100--4199\4122\067\Acad\Storm Sewer\Crossings.dwg Time: Feb 04, 2014 - 9:44am



**DETAIL FOR CROSSING
A STONE DRIVEWAY**

NO SCALE

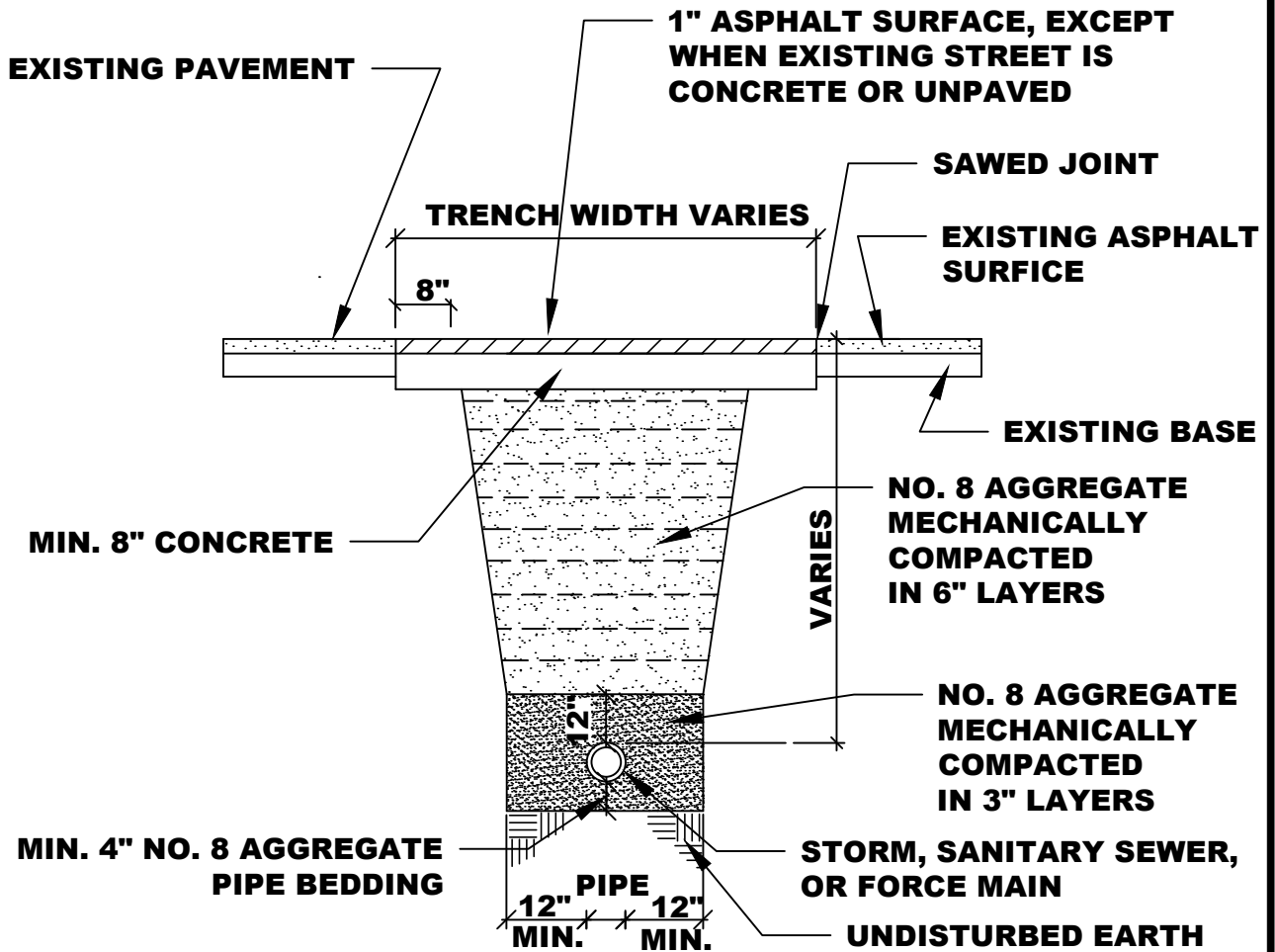
**SECTION 2
EXCAVATION, FILL, BACKFILL, AND GRADING
STANDARD CONSTRUCTION SPECIFICATIONS
STONE DRIVEWAY CROSSING
CITY OF SEYMOUR
SEYMOUR, INDIANA**



FIGURE 2-2

4122.067

File: S:\COL\4100--4199\4122\067\Acad\Storm Sewer\Crossings.dwg Time: Feb 04, 2014 - 9:44am



**DETAIL FOR CUTTING
AN ASPHALTIC STREET**

NO SCALE

NOTE:

1. WHERE EXISTING STREET IS CONCRETE SURFACE THE CONCRETE PATCH SHOWN SHALL MATCH THE EXISTING SURFACE AND BE BROOM FINISHED.
2. CONTRACTOR SHALL NOTIFY CITY THE PRECEDING DAY WORK IS TO BEGIN. THE CITY SHALL INSPECT AND APPROVE ALL WORK

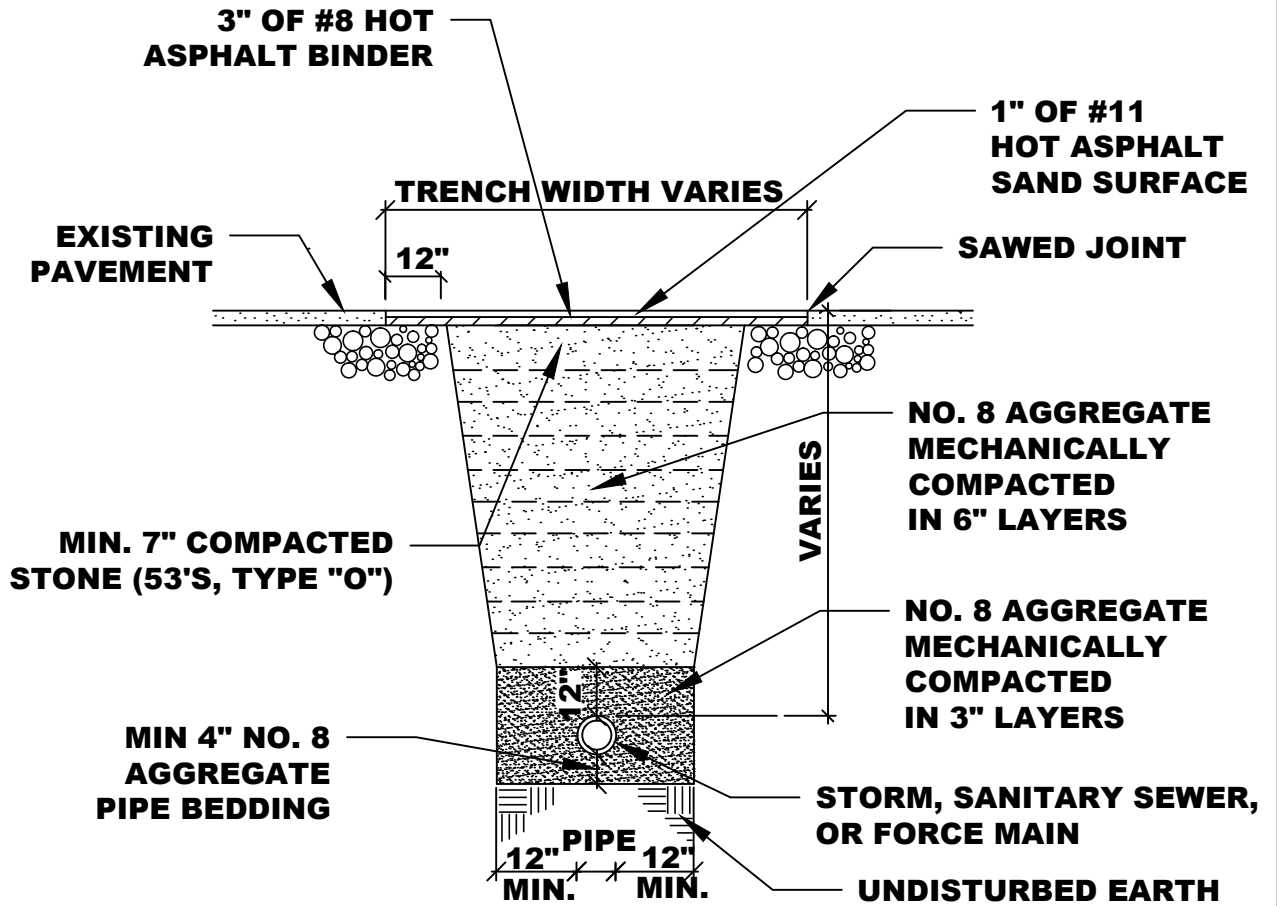
SECTION 2
EXCAVATION, FILL, BACKFILL, AND GRADING
STANDARD CONSTRUCTION SPECIFICATIONS
ASPHALT STREET CROSSING
CITY OF SEYMOUR
SEYMOUR, INDIANA



FIGURE 2-3

4122.067

File: S:\COL\4100--4199\4122\067\Acad\Storm Sewer\Crossings.dwg Time: Feb 04, 2014 - 9:44am



**DETAIL FOR CROSSING
AN ASPHALTIC DRIVEWAY**

NO SCALE

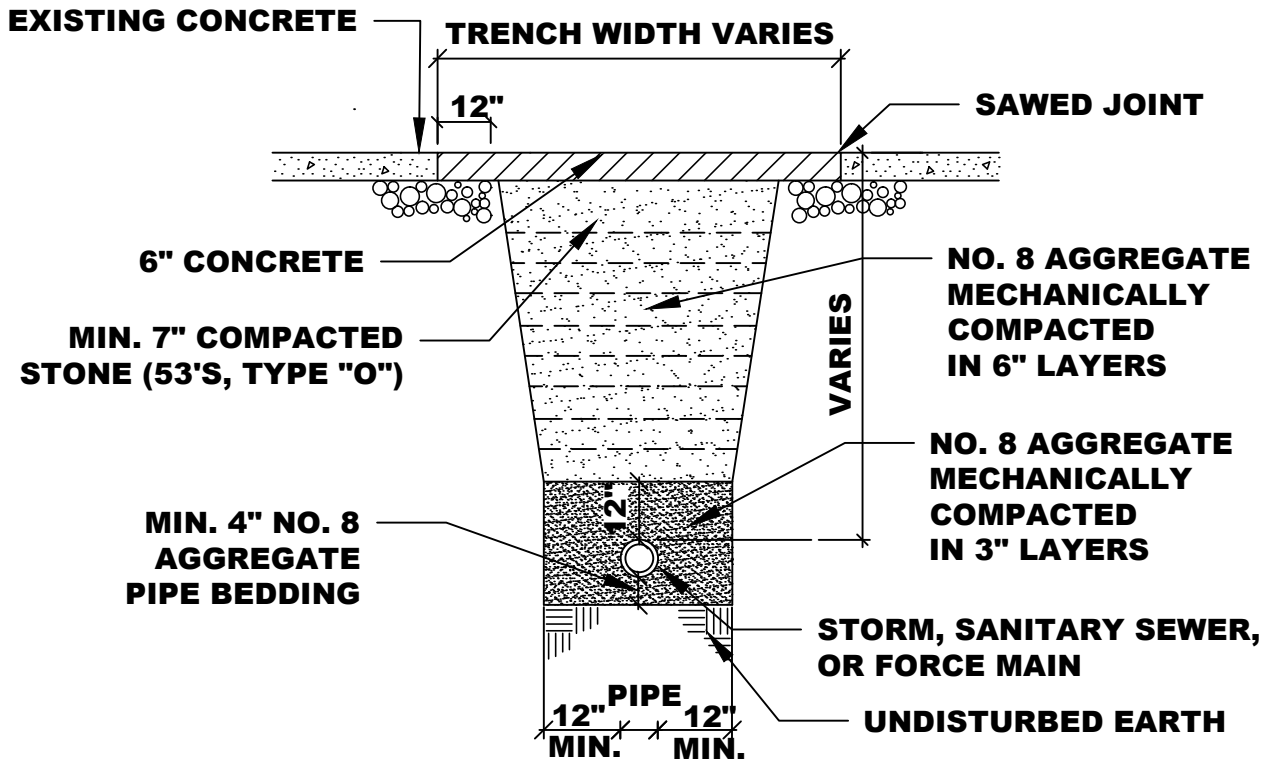
**SECTION 2
EXCAVATION, FILL, BACKFILL, AND GRADING
STANDARD CONSTRUCTION SPECIFICATIONS
ASPHALT DRIVEWAY CROSSING
CITY OF SEYMOUR
SEYMOUR, INDIANA**



FIGURE 2-4

4122.067

File: S:\COL\4100--4199\4122\067\Acad\Storm Sewer\Crossings.dwg Time: Feb 04, 2014 - 9:44am



DETAIL FOR CROSSING A CONCRETE DRIVEWAY

NO SCALE

SECTION 2
EXCAVATION, FILL, BACKFILL, AND GRADING
STANDARD CONSTRUCTION SPECIFICATIONS
CONCRETE DRIVEWAY CROSSING
CITY OF SEYMOUR
SEYMOUR, INDIANA



FIGURE 2-5

4122.067

SECTION 3

TRENCHLESS CONSTRUCTION

PART 1 -GENERAL

1.01 SUMMARY

- A. Work Included: Installation of all utilities required to be installed through the use of trenchless construction techniques.

PART 2-PRODUCTS

2.01 PIPE AND APPURTENANCES

- A. Polyvinyl Chloride (PVC):
 1. PVC pipe used for trenchless construction shall be AWWA C900 for pipe 4 inches through 12 inches and AWWA C905 for pipe from 14 inches through 36 inches. Pipe shall be furnished with integral elastomeric bell and spigot joints.
 2. All PVC pipe shall be restrained at each joint. Pipe joints shall be restrained with Megalug joint restraints series 1500 bell restraint harness, Series 1600 bell restraint harness, or equal.
 3. PVC pipe diameter shall conform to the O.D. of ductile iron pipe. The type of PVC material, nominal pipe size, standard dimension ratio (DR) and pressure rating shall be not less than pressure class 235 and not greater than DR-18.
 4. Markings on the pipe shall include the following: Nominal pipe size, type of plastic pipe material, DR number, AWWA Designation with which the pipe complies, manufacturer's name, and the seal or mark of the laboratory making the evaluation of the suitability of the pipe for the transport of potable water.
- B. High Density Polyethylene Pressure Pipe (HDPE):
 1. HDPE pressure rated pipe shall conform to the requirements of AWWA C906 for pipe from 4 inches through 63 inches. HDPE pipe shall be manufactured from material conforming to PE Code PE3608.
 2. HDPE pipe diameter shall conform to the O.D. of ductile iron pipe size (DIPS). The type of HDPE material, nominal pipe size standard dimension ratio (DR), and pressure rating shall be not less than pressure class 200 and not greater than a DR 9.
 3. Markings on the pipe shall include the following: Nominal pipe size, type of plastic pipe material, DR number, pressure class rating, manufacturer's

name, and the seal or mark of the laboratory making the evaluation of the suitability of the pipe for the transport of potable water.

4. Fittings for HDPE pipe shall conform to AWWA C906 and shall have the same pressure rating as the pipe in which they are installed.

C. Steel Casing Pipe:

1. All casing pipe shall be steel casing pipe designed for E-80 loading with minimum yield strength of 35,000 pounds per square inch.
2. If Contractor chooses to provide coated steel casing pipe, the coating must be installed on both the inside and outside of the casing pipe to prevent corrosion. The coating type must be capable of remaining on the casing pipe during installation

D. Tracer Wire: Tracer wire shall be installed on all trenchless piping. See Paragraph 2.05.G in Section 8 for tracer wire specifications.

E. Sacrificial Anode Bags:

1. Anode bags shall be 17 pound and/or 32 pound high-potential magnesium anode bags furnished with 10 linear feet of type TW No. 12 solid copper wire lead.
2. Copper sleeve is required to Cad weld wire lead of bag to the pipe being protected.
3. A 747 aerosol primer shall be used, primer adhesive shall be used to install handy cap. Bituminous coating shall be used when install anode bag leads to ductile iron pipe to protect cad-weld.

PART 3–EXECUTION

3.01 HORIZONTAL DIRECTIONAL DRILLING

- A. Contractor may use a drilling fluid which is completely biodegradable. Clay based drilling fluids will also be allowed. Drilling fluid shall be subject to the review of the City. Contractor shall provide his own clean water for drilling fluid. At no time shall the drilling fluid be discharged to a surface water. This includes drilling fluid that may surface along the directionally drilled pipe route.
- B. All drilling fluid and slurry that enters the initiation and termination excavations shall be removed and properly disposed of by Contractor. Contractor shall restore all disturbed areas to original condition.
- C. The boring unit shall have a tracking device which is capable of providing depth and location at all points of the boring path. As-Built/Record drawings showing horizontal and vertical locations of the conduit shall be created by Contractor based on the tracker information and submitted to the City.

- D. Upon completion of the directional drilling operation by Contractor, Contractor shall backfill the excavation, perform clean up and all site restoration. All surfaces shall be restored in kind with thicknesses matching those removed.

3.02 TUNNELING, BORING, JACKING, OR BORING AND JACKING

- A. The carrier pipe shall be the same material as specified for open cut installation in the adjacent pipe.
- B. Casing spacers shall be designed to guide and support the carrier pipe in the casing. Standard casing spacers shall consist of a 14 gauge AISI type 304 stainless steel risers. Each riser shall be equipped with a removable ultra high molecular weight polymer or glass reinforced plastic runner. Attachment hardware shall be AISI Type 304 stainless steel. Spacers shall have a minimum width of 8 inches. Standard casing spacers shall be Cascade Waterworks Manufacturing Model CCS or Pipeline Seal and Insulator, Inc. Model S8G or equal.
- C. All casing pipe shall be onsite before any jacking is to start. Once jacking operation is started it shall be continued without interruption until completion. The position for spacers shall adequately support the carrier pipe throughout the casing. A casing spacer shall be installed within one foot of each end of the casing, on each side of each pipe joint, and at a maximum spacing of 6 feet for carrier pipe. The carrier pipe shall be adjusted so that the end extends past the end of the casing 18 inches. After the carrier pipe is installed the end of the casing shall be sealed with 2-inch-thick planks and the spacing between the casing and carrier pipes shall be filled with brown sand.

3.03 HDPE FUSION WELDING

- A. Polyethylene pipe shall be joined using the butt fusion welding process. Provide a fused flanged adapter with ductile iron follower flange and a ductile iron flanged pipe for interconnections with ductile iron and/or PVC piping.
- B. Sections of polyethylene pipe shall be assembled and joined on the job site above ground. Pipe ends to be joined shall be cut square, then joined, by the heating and butt-fusion method in strict conformance with the manufacturer's printed instructions.
- C. The butt-fusion method for pipe jointing shall be carried out in the field by operators with prior experience in fusing polyethylene pipe with similar equipment using proper jigs and tools per standard procedures outlined by the pipe manufacturer. These joints shall have a smooth, uniform double-rolled back bead made while applying the proper melt, pressure, and alignment. It shall be the sole responsibility of Contractor to provide an acceptable butt-fusion joint. The replacement pipe shall be joined on the site in appropriate working lengths near the insertion pit.

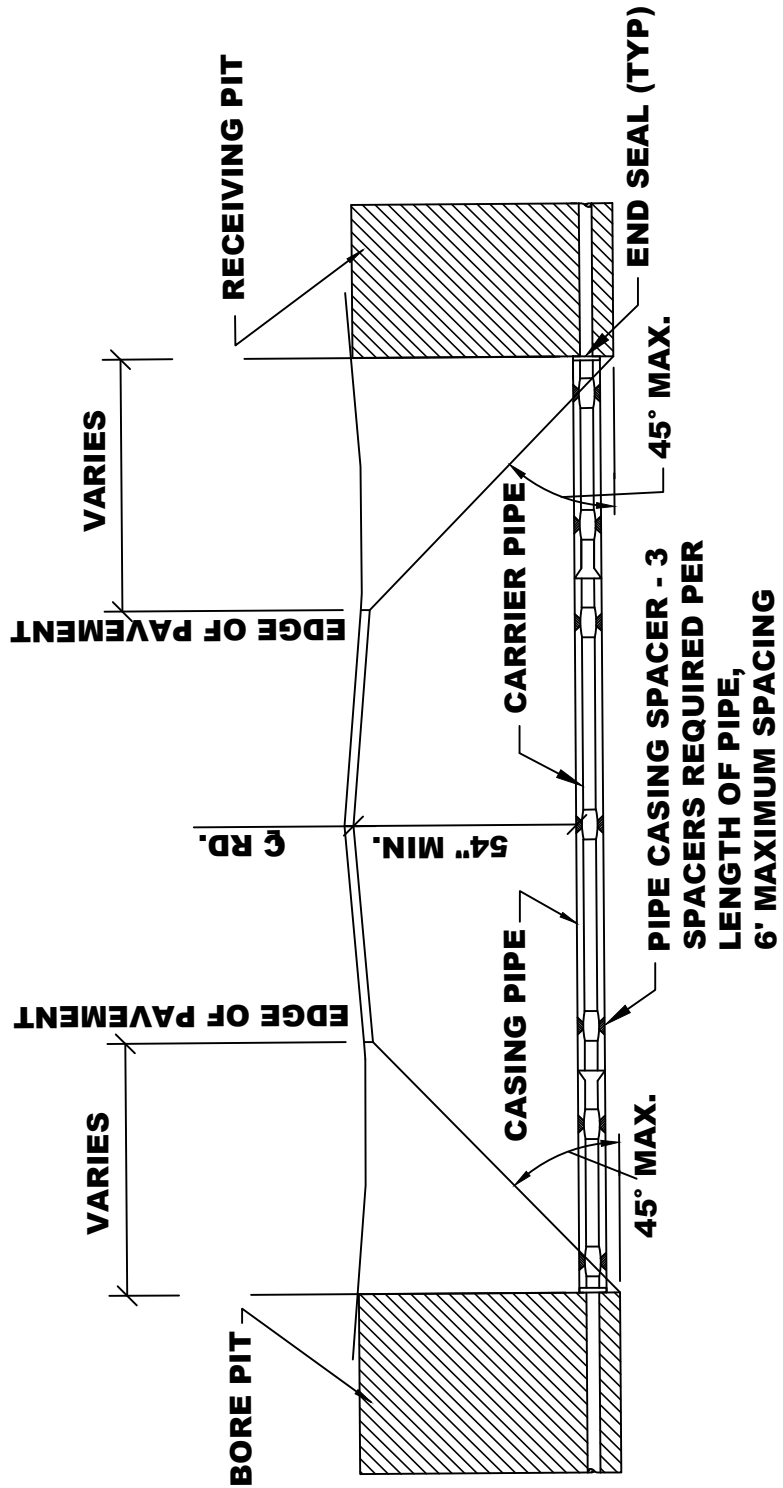
3.04 FINISHED PIPE

- A. The installed pipe shall be continuous over the entire length and shall be free from visual defects, such as foreign inclusions, concentrated ridges, discoloration, pitting, varying wall thickness, and other deformities. Pipe with gashes, nicks, abrasions, or any such physical damage which may have occurred during storage and/or handling, which are deeper than 10% of the wall thickness shall not be used and shall be removed from the construction site.

3.05 TESTING

- A. Testing of pipes installed with trenchless techniques shall be in accordance with Section 8.

END OF SECTION



TYPICAL BORING CASING PIPE

NO SCALE

**SECTION 3
TRENCHLESS CONSTRUCTION
STANDARD CONSTRUCTION SPECIFICATIONS
TYPICAL BORE CASING PIPE
CITY OF SEYMOUR
SEYMOUR, INDIANA**

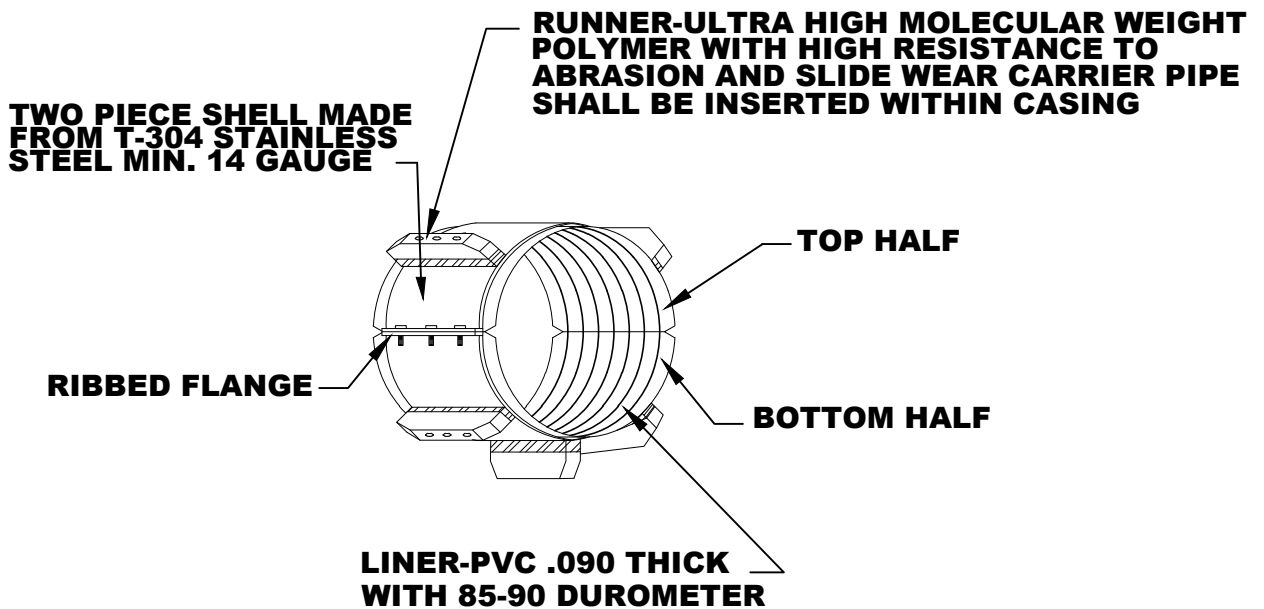


FIGURE 3-1

4122.067

PLACEMENT OF SPACERS ON CARRIER PIPE

PVC CARRIER - ONE SPACER SHALL BE PLACED ON THE SPIGOT END OF EACH SEGMENT AT THE LINE MARKING THE LIMITS OF INSERTION INTO THE BELL. WHEN THE JOINT IS COMPLETE, THE SPACER SHALL BE IN CONTACT WITH THE BELL OF THE JOINT SO THAT THE SPACER PUSHES THE JOINT AND RELIEVES COMPRESSION WITHIN THE JOINT. SUBSEQUENT SPACERS SHALL BE PLACED AT 6" INTERVALS



CASING SPACERS

NO SCALE

File: S:\COL\4100--4199\4122\067\Acad\Sanitary\Casing Spacers.dwg Time: Feb 04, 2014 - 9:44am

**SECTION 3
TRENCHLESS CONSTRUCTION
STANDARD CONSTRUCTION SPECIFICATIONS
CASING SPACERS
CITY OF SEYMOUR
SEYMOUR, INDIANA**



FIGURE 3-2

4122.067

SECTION 4
SEEDING AND SODDING

PART 1-GENERAL

1.01 SUMMARY

- A. Work Included:
 - 1. Preparation of subsoil.
 - 2. Placing topsoil.
 - 3. Seeding, sodding, mulching and fertilizing.
 - 4. Maintenance.
- B. Except for paved, riprapped, or built-up areas, all areas of the right-of-way which are disturbed shall be seeded or sodded. Surfaces on 3 to 1 slope or less may either be seeded or sodded but surfaces on greater than 3 to 1 slope shall be sodded.

1.02 REFERENCES

- A. FS O-F-241–Fertilizers, Mixed, Commercial.
- B. Standard Specifications: Unless otherwise indicated, Standard Specifications shall refer to the, State of Indiana Department of Transportation, Standard Specifications, Latest Edition, including all issued supplemental specifications.

1.03 QUALITY ASSURANCE

- A. Sod: Minimum age of 18 months, with root development that will support its own weight without tearing when suspended vertically by holding the upper two corners.

1.04 DELIVERY, STORAGE, AND PROTECTION

- A. Deliver grass seed mixture in sealed containers.
- B. Deliver sod on pallets or in rolls. Protect exposed roots from dehydration. Do not deliver more sod than can be laid within 24 hours.
- C. Deliver fertilizer in waterproof bags showing weight, chemical analysis, and name of manufacturer.

PART 2–PRODUCTS

2.01 SEED MIXTURE

- A. Seed mix Type U or R per Standard Specifications. Use certified seed. Do NOT use bent or Poa Annua. Each seed lot will be subject to sampling and testing by the state seed laboratory.
- B. Weed content shall not exceed 0.5% in mixture.

2.02 SOD

- A. Follow Section 621 of the INDOT Specifications.
- B. Netting or fabric for sod reinforcement shall be in accordance with Section 621 of the INDOT Specifications.
- C. Anchorage staples shall be in accordance with Section 621 of the INDOT Specifications.

2.03 SOIL MATERIALS

- A. Topsoil: Fertile, agricultural soil, typical for locality, capable of sustaining vigorous plant growth, taken from drained site; free of subsoil, clay, or impurities, plants, weeds, roots and rocks; pH value of minimum 5.4 and maximum 7.0.
- B. Topsoil from the site may be used if it meets the above requirements.

2.04 ACCESSORIES

- A. Mulching material shall be oat or wheat straw, free from weeds, foreign matter detrimental to plant life, and dry. Hay or chopped cornstalks are not acceptable.
- B. Fertilizer shall be FS O-F-241, Type I, Grade A; recommended for grass, with 50% of the elements derived from organic sources; of proportion necessary to eliminate any deficiencies of topsoil to the following proportions: Nitrogen 10%, phosphoric acid 10%, soluble potash 10%.
- C. Water shall be clean, fresh, and free of substances or matter which could inhibit vigorous growth of grass.

PART 3–EXECUTION

3.01 EXAMINATION

- A. Verify that prepared soil base is ready to receive the work of this section.

3.02 PREPARATION OF SUBSOIL

- A. Prepare subsoil to eliminate uneven areas and low spots. Maintain lines, levels, profiles, and contours. Make changes in grade gradual. Blend slopes into level areas.
- B. Remove foreign materials, weeds, and undesirable plants and their roots. Remove contaminated subsoil in accordance with local, state, and federal regulations.
- C. Scarify subsoil to a depth of 3 inches where topsoil is to be placed. Repeat cultivation in areas where equipment used for hauling and spreading topsoil has compacted subsoil.

3.03 PLACING TOPSOIL

- A. Spread topsoil to a minimum depth of 4 inches over area to be seeded. Rake until smooth.
- B. Place topsoil during dry weather and on dry unfrozen subgrade.
- C. Remove vegetable matter and foreign nonorganic material from topsoil while spreading.
- D. Grade topsoil to eliminate rough, low or soft areas, and to ensure positive drainage.
- E. Manually spread topsoil around trees, plants, and buildings to prevent damage.
- F. Leave stockpile area and site clean and raked, ready to receive landscaping.

3.04 FERTILIZING

- A. Apply fertilizer at a rate of 17 pounds per 1,000 square feet.
- B. Apply after smooth raking of topsoil and prior to installation of seed or sod, no more than 18 hours before seeding or 48 hours before sodding.
- C. Do not apply fertilizer at same time or with same machine as will be used to apply seed.
- D. Mix thoroughly into upper 2 inches of topsoil.
- E. Lightly water to aid the dissipation of fertilizer.

3.05 SEEDING

- A. Apply seed at a total rate of 3-1/2 pounds per 1,000 square feet. Apply evenly in two intersecting directions. Rake in lightly or roll the seeded area after seeding.
- B. Do not seed areas in excess of that which can be mulched on same day.

- C. Planting season shall be between April 15 and June 15 or between August 15 and October 15.
- D. Do not sow immediately following rain, when ground is too dry, or during windy periods.
- E. Immediately following seeding, apply mulch.
 - 1. Minimum Spread Rate: 1-1/2 tons per acre.
 - 2. Maximum Depth: 1-1/2 inches to 2 inches.
- F. Apply water with a fine spray immediately after each area has been mulched and on a daily basis to keep straw in place.
- G. Seeding shall be maintained by Contractor until grass is well established. Grass is well established when it covers the entire seeded areas to a height of 2 inches.

3.06 EROSION MAT

- A. Place erosion mat immediately after seeding or sodding operations have been completed. Before mat placement, remove all material or clods over 1 1/2 inches in diameter and all organic material or other foreign material which interfere with the mat bearing completely on the soil or sod.
- B. Any small stones or clods which prevent contact of the mats with the soil shall be pressed in the soil with a small lawn-type roller or by other effective means. The mat shall have its lateral edge so impressed in the soil as to permit runoff water to flow over it.
- C. The matting strips shall be rolled on or laid in direction of flow. Spread mat evenly, smoothly, in a natural position without stretching and with all parts bearing on soil, and place blanket with netting on top. Overlap adjacent strips at least 4 inches. Overlap strip ends at least 10 inches. Make overlaps with the upgrade section on top.
- D. Bury upgrade end of each strip of fabric or blanket at least 6 inches in a vertical slot cut in the soil and press soil firmly against the embedded fabric or blanket.
- E. Anchor mats in place with vertically driven staples, driven until their tops are flush with the soil. Space staples at 3-foot centers along mat edges and stagger space at 3-foot centers through the center. Place staples at 10-inch centers at end or junction slots.
- F. Reseed areas damaged or destroyed during erosion mat placing operations as specified for original seeding.
- G. Dispose of surplus excavated materials and all stones, clods, or other foreign material removed in the preparation of the seeded soil or sodded surface before placing mat.

- H. Following mat placement, uniformly apply water to the area to moisten seedbed to 2-inch depth and in a manner to avoid erosion.
- I. Maintain erosion mat and make satisfactory repairs of damage from erosion, traffic, fires or other causes until work acceptance.

3.07 LAYING SOD

- A. Moisten prepared surface immediately prior to laying sod.
- B. Lay sod immediately after delivery to site to prevent deterioration.
- C. Lay sod tight with no open joints visible, and no overlapping; stagger end joints 12 inches minimum. Do not stretch or overlap sod pieces.
- D. Lay smooth. Align with adjoining grass areas.
- E. Place top elevation of sod 1/2-inch below adjoining edging, paving, or curbs.
- F. On slopes 4 to 1 and steeper, sod will be secured with wooden pegs at a maximum of 24 inches on center.
- G. On slopes 2 to 1 and steeper, lay sod perpendicular to slope and secure every row with wooden pegs at maximum 2 feet on center. Drive pegs flush with soil portion of sod.
- H. All sod placed in ditches, flumes, or other appurtenances where a concentrated flow of water may be expected shall be staked regardless of the slope.
- I. Water sodded areas immediately after installation. Saturate sod to 4-inch depth of soil.
- J. No frozen sod shall be laid and no sod shall be laid on frozen soil. Sodding is permitted only when the temperature is above 35°F.

3.08 MAINTENANCE

- A. Seeding shall proceed concurrently with the main construction. Seeding shall be maintained by Contractor until grass is well established. Grass is well established when it covers the entire seeded areas to a height of 2 inches.

END OF SECTION

SECTION 5

HOT MIX ASPHALT PAVING

PART 1-GENERAL

1.01 SUMMARY

- A. Work includes Hot Mix Asphalt (HMA) paving, tack coat, casting adjustments, pavement striping, and traffic control.
- B. Contractor is cautioned that existing private and public roads and shoulders may not hold up to typical construction traffic or activities. Contractor shall replace all roads shoulders, and paved areas damaged during the project in accordance with this section. In addition, gravel shoulders, gravel roads and parking areas that are damaged shall also be repaired.

1.02 REFERENCES

- A. Standard Specifications: Unless otherwise indicated, Standard Specifications shall refer to the State of Indiana Department of Transportation, Standard Specifications, Latest Edition including all issued supplemental specifications.

1.03 DEFINITIONS

- A. Street or road shall include streets, roads, driveways, and parking lots.

PART 2-PRODUCTS

2.01 HMA PAVEMENT

- A. Asphaltic pavement shall be Section 402 HMA Type B. Asphaltic binder for lower course and upper course shall be PG 64-22 per Section 902 of the INDOT Specifications.
- B. Aggregate shall conform to the requirements of Section 904 of the INDOT Specifications. Aggregate for the intermediate course shall be nominal size of 3/4-inch. Aggregate for the surface course shall be nominal size of 1/2-inch.
- C. Replacement of paved surfaces shall be as shown on Figure 2-3.
- D. Materials for tack coat shall conform to the requirements of Section 406 of the INDOT Specifications.

2.02 PAVEMENT MARKING MATERIALS

- A. Pavement marking material shall be thermoplastic pavement markings and shall conform to the requirements of Section 921 of the INDOT Specifications.

PART 3–EXECUTION

3.01 ALLOWABLE REMOVAL OF PAVEMENT

- A. Contractor shall remove asphalt pavement and road surface as a part of the general excavation. The width of pavement removed shall be the minimum possible and acceptable for convenient and safe installation of structures, utilities, and appurtenances.
- B. All asphalt pavement shall be cut on neat, straight lines and shall not be damaged beyond the limits of the excavation. Should the cut edge be damaged, a new cut shall be made in neat, straight lines parallel to the original cut encompassing all damaged areas. Pavement removal shall be extended to a seam or joint if seam or joint is within 3 feet of damaged pavement.

3.02 CASTING ADJUSTMENTS

- A. All new and existing manhole castings and valve boxes within the paving limits of the street, which require adjustment, shall be adjusted to match the finished asphaltic surface. Adjustments shall not be made greater than 48 hours prior to the anticipated time of paving. Contractor shall furnish Class 1 barricades with flashers on all adjusted castings until paving has been completed. Tops of castings and valve boxes shall be oiled or protected by other methods to prevent sealing of lids and filling of lift holes during paving. Upon completion of paving operations, Contractor shall check all castings and valve boxes to insure that the lids are clean and operational.

3.03 TACK COAT

- A. All work shall be in accordance with the Standard Specifications.
- B. If asphaltic surface is applied to an existing street or is not applied the same day as intermediate course, the existing street or intermediate course shall be tack coated prior to surface paving. Prior to placement of tack coat, the streets shall be thoroughly cleaned and broomed. Tack coat shall be applied at a rate of 0.10 gallons per square yard immediately prior to placement of asphaltic surface course.
- C. In situations where traffic must be maintained, tack coat shall not be placed on the traveled half of the street until traffic can be switched to the new pavement.

3.04 JOINTS

- A. Joints between old and new pavements or between successive day's work shall be constructed and treated as to insure thorough and continuous bond between the old and new mixtures. Transverse construction joints shall be constructed by cutting the material back for its full depth so as to expose the full depth of the course. Where a header is used, the cutting may be omitted provided the joint conforms to the specified thickness. These joints shall be treated with tack coat material applied with a hose and spray nozzle attachment to fully coat the joint surface.

- B. The longitudinal joint shall be made by overlapping the screed on the previously laid material for a width of not more than 2 inches and depositing a sufficient amount of asphaltic mixture so that the finished joint will be smooth and tight. Longitudinal joints in the surface course shall at no time be placed immediately over similar joints in the intermediate course beneath. A minimum distance of 12 inches shall be permitted between the location of the joints in the intermediate course and the location of similar joints in the surface course above.

3.05 FINISHING ROADWAY

- A. The finished base course shall be fine-graded in preparation for HMA paving. Base course ramps at all existing pavement shall be removed to provide a full depth butt joint. Base course around manhole castings and valve boxes shall be hand-trimmed and compacted with a vibratory plate compactor.
- B. Asphaltic ramps around manholes on existing intermediate course to receive surface course shall be removed. Asphaltic ramps shall be installed on all manholes and at all butt joints in areas to receive intermediate course only.

3.06 TESTING HOT MIX ASPHALT

- A. The City may require samples of HMA pavement for testing. Contractor shall cut samples from the finished pavement where marked by the City and patch the sample area. Samples for sieve analysis and asphalt content will be taken by the City prior to placement.

3.07 HOT MIX ASPHALT PAVING

- A. HMA paving work shall include the construction of plant-mixed hot mix asphalt pavement in the areas shown on the drawings. All work shall be performed in accordance with Section 402 of the INDOT Specifications.
- B. Prior to commencement of paving operations, Contractor shall examine the finished road bed areas of suspected instability. Any areas of concern shall be reported to the City.
- C. The pavement structure for new roads shall be determined from the standard cross sections provided on the drawings.

3.08 PAVEMENT STRIPING

- A. Where required, Contractor shall provide painted pavement markings.
- B. Two-way traffic shall be maintained at all times.
- C. Centerline marking shall be double 4-inch solid yellow line, placed at the marked centerline.
- D. Traffic lane marking shall be single 4-inch broken white line, placed 12 feet from median curb flange or as requested by the City. Turning lane markings and

crosswalk marking shall be 8 inch and 6 inch solid white, respectively. Stop bars shall be 18 inch and solid white.

- E. All markings shall be applied in accordance with Section 808 of the INDOT Specifications and the Manual on Uniform Traffic Control Devices.
- F. Markings shall be placed at locations noted within 1-inch tolerance.

3.09 TRAFFIC CONTROL

- A. Contractor shall conduct its work to minimize disruption of traffic on the job site and adjacent streets and alleys. Where construction is in an areas having only one vehicular access, Contractor shall conduct it work to avoid or minimize blockage of such access. Blocking of streets or providing detours shall only be done if allowed by the City. Safe access shall be provided all times for local traffic when Contractor is not working. Contractor shall keep local police and fire departments informed as to traffic access status as the work proceeds.
- B. Contractor shall furnish and install all necessary flagmen, barricades, signs, warning lights, and appurtenances to provide for safe and convenient control of traffic throughout the Project site. Barricading, signing, and flagging shall be accomplished in strict accordance with the Manual on Uniform Traffic Control Devices and the INDOT Specifications.

END OF SECTION

SECTION 6

CONCRETE CURB AND GUTTER, SIDEWALKS, AND DRIVEWAYS

PART 1-GENERAL

1.01 SUMMARY

- A. Work includes concrete curb and gutter, sidewalks, and driveways.

1.02 REFERENCES

- A. Standard Specifications: Unless otherwise indicated, Standard Specifications shall refer to the State of Indiana Department of Transportation, Standard Specifications, Latest Edition including all issued supplemental specifications.
- B. AASHTO M148 Standard Specifications for Liquid Membrane-Forming Compounds for Curing Concrete.

1.03 QUALITY ASSURANCE

- A. Unless otherwise specified, all curb and gutter, sidewalks, and driveway construction shall meet the requirements of the Standard Specifications.

PART 2-PRODUCTS

2.01 CONCRETE

- A. All concrete shall conform to Section 604 of the Standard Specifications for sidewalk and driveways and Section 605 for curb and gutter.

2.02 CURING COMPOUND

- A. Liquid curing compounds shall conform to the requirements of the Standard Specifications for Liquid Membrane-Forming Compounds for Curing Concrete, AASHTO Designation M148, Type 2, White Pigmented, as required by the City.

PART 3-EXECUTION

3.01 BASE PREPARATION-CURB AND GUTTER

- A. The base course beneath the curb and gutter shall be trimmed or filled as necessary to provide a full depth of curb and gutter. Prior to placement of concrete, the base shall be thoroughly compacted and moistened.

3.02 BASE PREPARATION–SIDEWALKS AND DRIVEWAYS

- A. The subgrade shall be thoroughly compacted and finished to a trim, firm surface. All soft or unsuitable material shall be removed and replaced with suitable material.
- B. A minimum 2-inch-thick layer of sand, sand and gravel, or base course shall be placed under all sidewalks. This material shall be thoroughly moistened and compacted before the concrete is placed.

3.03 FORMS

- A. Forms shall be of metal (or wood for straight line work only) and of sufficient strength to resist distortion or displacement. Metal forms shall be used to construct a curb and gutter cross section. Forms shall be full depth of the required work. Facing boards, if used, shall be built so as to obtain the cross section called for on the drawings. Forms shall be securely staked and held firmly to line and grade. Forms shall be cleaned thoroughly and oiled before reuse.
- B. All curved curb and gutter shall form smooth curves and shall not be a series of chords. Radius forms shall be used for all curved curb and gutter where the radius of curvature is 100 linear feet or less.

3.04 PLACING AND FINISHING CONCRETE.

- A. Unless otherwise specified, concrete shall be placed in accordance with the Standard Specifications.
- B. Concrete shall be thoroughly tamped to remove all voids. The exposed surfaces of the curb and gutter shall be thoroughly troweled and finished with a brush at right angles to the line of the curb and gutter. The back edge of the curb, the edge of the gutter adjacent to the pavements, and edges adjacent to expansion joints shall be rounded with a 1/4-inch radius edger. Honeycombed areas along the back of the curb shall be pointed with mortar.
- C. Before final finishing of curb and gutter, a 10-foot straight edge shall be used to check the surface. Any areas showing a variation of more than 1/4-inch from the straight edge shall be corrected. Final finishing shall be delayed a sufficient time so that excess water and grout will not be brought to the surface.
- D. Concrete for sidewalk within right-of-way shall be placed to a minimum thickness of 4 inches, except at driveways and alleys, which shall have a minimum thickness equal to that of the driveway and alleys. Driveways within right-of-way shall have a minimum thickness of 10 inches for industrial and commercial driveways and a minimum thickness of 6 inches for residential driveways. The concrete shall be thoroughly spaded and tamped to remove all voids. The surface of the driveway or sidewalk shall be thoroughly

troweled and finished with a brush at right angles to the driveways or sidewalk line.

3.05 MACHINE FORMED CURB AND GUTTER

- A. Contractor may elect to use a machine for placing, forming, and consolidating concrete curb and gutter. If a machine is used, the resulting curb and gutter shall be of such a quality as to equal or exceed that produced by the method described above.

3.06 REJECT SECTIONS

- A. At locations determined by the City, the curb and gutter shall be warped so as to reject the flow of water. The transition from a standard section to a reject section shall not be abrupt but shall be a minimum of 10 feet in length.

3.07 JOINTING—CURB AND GUTTER

- A. A 3/4-inch expansion joint filler shall be placed through the curb and gutter at the radius points of all intersection curbs. This expansion joint filler shall extend through the entire thickness of concrete and shall be perpendicular to the surface and at right angles to the line of the curb and gutter.
- B. At intervals of not more than 10 feet, a contraction joint shall be tooled to a depth of 1/5 of the total concrete thickness with a 1/4-inch radius jointer. The contraction joint shall be at right angles to the line of the curb and gutter.
- C. If machine-formed curb and gutter is provided by Contractor, Contractor shall create a plane of weakness at all joints that is sufficient to cause contraction cracking at the joints.
- D. Contractor may saw contraction joints. The depth of cut shall be a minimum of 1/5 of the total concrete thickness. Sawing shall be done as soon as practicable after the concrete has set sufficiently to preclude raveling during the sawing and before any shrinkage cracking takes place in the concrete. If this method results in random cracking, Contractor will be required to tool the contraction joints as specified above.
- E. The use of steel separator plates will not be allowed.

3.08 JOINTING—SIDEWALKS AND DRIVEWAYS

- A. Concrete sidewalk shall be cut into rectangular blocks approximately 5 feet long. The cut must extend at least 1/5 of the total thickness of concrete. The edges of the sidewalk along forms and joints shall be rounded with an edging tool of 1/4-inch radius. All joints shall be at right angles to the centerline of the sidewalk.
- B. Concrete driveways shall be jointed in approximately square sections. The depth of the joint and the finishing of the edges shall be the same as for concrete sidewalk.

3.09 EXPANSION JOINTS

- A. A 1-inch-thick expansion joint filler shall be placed between curb ramps and back of curb.
- B. A 3/4-inch-thick expansion joint shall be placed at all sidewalk corners, between sidewalks and buildings, between sidewalks and curb and inlet castings, and between back of curb and sidewalk.

3.10 SLOPE

- A. Sidewalk cross slope shall be 1/4-inch per foot.

3.11 CURB RAMP

- A. Curb ramps shall be constructed in accordance with the Standard Specifications

3.12 INLET CASTING ADJUSTMENT

- A. Inlet casting shall be adjusted to grade as required for the installation of the new curb and gutter. Inlet casting backs shall be adjusted for a depressed flow line at all inlets in the low points (0.72 feet); all other inlet shall be adjusted for a normal flow line (0.50 feet).

3.13 UTILITY MARKINGS

- A. The ends of utility service lines (sewer, water, gas, and electrical conduits) shall be marked during installation. The curb top shall be marked immediately adjacent to these utility markers. Curb markers shall be 2 inches in height and shall consist of a "W" for water, "S" for sewer, "G" for gas and "E" for electric and blank conduits. Markings shall be embossed a minimum of 1/4-inch deep and be 3/8-inch thick.

3.14 CURING

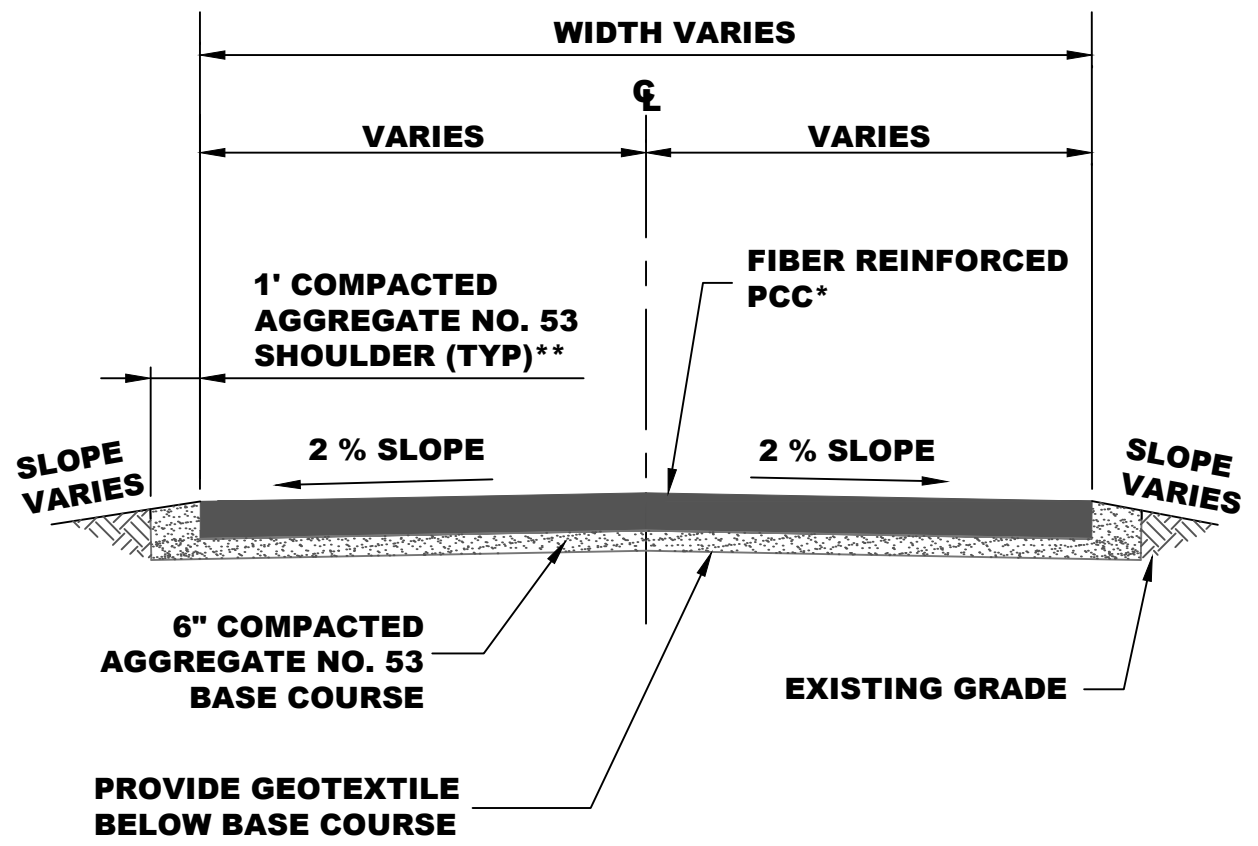
- A. As soon after finishing operations as the free water has disappeared, the concrete surface shall be sealed by spraying on it a uniform coating of curing material in such a manner as to provide a continuous water impermeable film on the entire concrete surface.
- B. The material shall be applied to form a uniform coverage at the rate of not less than one-half gallon per 100 square feet of surface area.
- C. Within 30 minutes after the forms have been removed, the edges of the concrete shall be coated with the curing compound applied at the same rate as on the finished surface.

3.15 PROTECTION OF CONCRETE

- A. Contractor shall erect and maintain suitable barricades to protect the new concrete. Where it is necessary to provide for pedestrian traffic, Contractor shall construct adequate crossings. Crossing construction shall be such that no load is transmitted to the new concrete.
- B. Any part of the work damaged or vandalized prior to final acceptance shall be repaired or replaced.
- C. Pedestrian traffic shall not be permitted over new concrete prior to 72 hours after application of curing material. Vehicular traffic shall not be permitted over newly placed concrete within seven days after completion when temperatures are 70°F or higher, 10 days when temperatures are not lower than 60°F and up to a maximum of 21 days when the temperatures are generally lower than 60°F.

END OF SECTION

File: S:\COL\4100--4199\4122\067\Acad\Concrete\S2-12.dwg Time: Feb 04, 2014 - 9:44am



**NEW CONCRETE
DRIVE SECTION**
NO SCALE

NOTES:
 *10" for commercial and industrial drives, 6" for residential drives
 **For commercial and industrial drives only

**SECTION 6
 CONCRETE CURB AND GUTTER, SIDEWALKS, AND DRIVEWAYS**
 STANDARD CONSTRUCTION SPECIFICATIONS
 NEW CONCRETE PAVEMENT SECTION
 CITY OF SEYMOUR
 SEYMOUR, INDIANA

**STRAND
ASSOCIATES®**

FIGURE 6-1
4122.067

SECTION 7
CAST-IN-PLACE CONCRETE

PART 1–GENERAL

1.01 SUMMARY

- A. Work Included:
 - 1. All cast-in-place concrete.
 - 2. PVC and hydrophilic waterstops, expansion joint fillers, bonding agents, patching mortars, curing compounds, nonshrink grout, grout topping, floor sealer and other related items and accessories.

1.02 REFERENCES

- A. ACI 211.1–Selecting Proportions for Normal, Heavyweight, and Mass Concrete.
- B. ACI 301–Structural Concrete for Buildings.
- C. ACI 304–Recommended Practice for Measuring, Mixing, Transporting, and Placing Concrete.
- D. ACI 305R–Hot Weather Concreting.
- E. ACI 306R–Cold Weather Concreting.
- F. ACI 308–Standard Practice for Curing Concrete.
- G. ACI 309–Guide for Consolidation of Concrete.
- H. ACI 318–Building Code Requirements for Reinforced Concrete.
- I. ASTM C31–Making and Curing Concrete Test Specimens in the Field.
- J. ASTM C33–Concrete Aggregates.
- K. ASTM C39–Compressive Strength of Cylindrical Concrete Specimens.
- L. ASTM C40–Organic Impurities in Fine Aggregates for Concrete.
- M. ASTM C94–Ready-Mixed Concrete.
- N. ASTM C143–Slump of Portland Cement Concrete.
- O. ASTM C150–Portland Cement.
- P. ASTM C172–Standard Practice for Sampling Freshly Mixed Concrete.

- Q. ASTM C156–Test for Water Retention by Concrete Curing Materials.
- R. ASTM C231–Air Content of Freshly Mixed Concrete by the Pressure Method.
- S. ASTM C260–Air-Entraining Admixtures for Concrete.
- T. ASTM C309–Liquid Membrane Forming Compounds for Curing Concrete.
- U. ASTM C494–Chemical Admixtures for Concrete.
- V. ASTM C618–Fly Ash and Raw or Calcinated Natural Pozzolan for Use as a Mineral Admixture in Portland Cement Concrete.
- W. ASTM D994–Preformed Expansion Joint Filler for Concrete (Bituminous Type).
- X. ASTM D1752–Preformed Sponge Rubber and Cork Expansion Joint Fillers for Concrete Paving and Structural Construction.

PART 2–PRODUCTS

2.01 CEMENT

- A. All cement used shall be Portland Cement and shall conform to ASTM C150 and shall be Type I or Type III. All cement shall be the product of one reputable manufacturer and mill.
- B. Cement shall be stored in a dry, weather-tight, properly ventilated structure with the floor raised not less than 1 foot above the ground.

2.02 FLY ASH

- A. All fly ash used as an admixture in Portland cement concrete shall be Class C or F conforming to the requirements of ASTM C618.

2.03 AGGREGATE

- A. All aggregates shall be washed and shall consist of natural sand, gravel, or crushed rock and shall have clean, hard, durable, uncoated grains of strong minerals. The amounts of deleterious substances present in the fine and coarse aggregate expressed in percentages by weight shall not exceed the following:

<u>Deleterious Substance</u>	Aggregate	
	<u>Fine</u>	<u>Course</u>
Clay Lumps and Friable Particles	3.0	3.0
Coal and Lignite	0.5	0.5
Mineral finer than No. 200 sieve	3.0	----
Soft Fragments	3.0	3.0
Chert*	----	5.0
Sum of Chert and Clay Lumps		5.0

*Material classified as chert and having a bulk specific gravity of less than 2.45. The

percentage of chert shall be determined on the basis of the weight of chert in the sample retained on a 3/8-inch sieve divided by the weight of the total sample.

- B. The combined amount of all deleterious substances in an aggregate shall not exceed 5 percent of the weight of the aggregate.
- C. If required by the City, sodium sulfate soundness tests (ASTM Designation C88) shall be performed on the aggregate. When the aggregate is subjected to 5 cycles, the weight loss shall not exceed 12%. Samples of proposed aggregates shall be submitted to an independent laboratory for testing in advance of concrete work. All testing shall be performed in accordance with ASTM Designation C33. Certified test results shall be submitted to the City confirming that aggregate complies with all stated specifications. Report shall identify source of aggregate and absorbed water.
- D. Fine aggregate shall be well graded from coarse to fine and shall conform to the following requirements:

Percentage by Weight	
Passing 3/8-inch sieve	100
Passing No. 4 sieve	95-100
Passing No. 8 sieve	80-100
Passing No. 16 sieve	50-85
Passing No. 30 sieve	25-60
Passing No. 50 sieve	5-30
Passing No. 100 sieve	0-10

- E. Gradation of fine aggregate shall be reasonably uniform and not subject to the extreme percentages of gradation specified above. The fineness modulus shall be not less than 2.3 or more than 3.1, nor shall the fineness modulus of any sample vary by more than +0.20 from the fineness modulus of the representative sample used in proportioning the concrete.
- F. If required by the City, fine aggregate shall be subjected to the color-metric test for organic impurities (ASTM C40) and shall not produce a color darker than Figure 1, unless they pass the mortar strength test. Aggregate producing color darker than Figure 2 shall not be used in any event.
- G. Coarse aggregate shall be well graded from coarse to fine, and when tested by laboratory sieves having square openings shall conform to the following requirements:

	Percentage by Weight Aggregate	
	3/4-inch Stone	1-1/2-inch Stone
Passing 2-inch sieve	---	100
Passing 1-1/2-inch sieve	---	90-100
Passing 1-inch sieve	100	20-55
Passing 3/4-inch sieve	90-100	0-15
Passing 3/8-inch sieve	20-55	0-5
Passing No. 4 sieve	0-10	---
Passing No. 8 sieve	0-5	---

- H. The 3/4-inch aggregate shall be used in concrete members no thinner than 4 inches and less than 10 inches thick. A blend of 3/4-inch and 1 1/2-inch aggregate shall be used in members 10 inches thick and thicker with the 3/4-inch aggregate comprising between 35% and 65% of the total course aggregate. When members thinner than 10 inches are placed monolithically with members thicker than 10 inches, the aggregate requirements for the thinner member shall apply.
- I. Aggregates must be allowed to drain for at least 12 hours before being used. The ground upon which aggregates are stored must be hard, firm, well-drained and free from all vegetable matter. Various sizes of aggregates must be stored separately, and if they have become contaminated or merged with each other, they shall not be used.

2.04 WATER

- A. Water used in mixing concrete shall be clean and free from injurious amounts of oil, alkali, organic matter, or other deleterious substances.

2.05 ADMIXTURES

- A. Water Reducing Admixture shall be Pozzolith 200N by BASF Admixtures, Inc., Daracem 19 by Grace or equal. Water reducing admixture shall conform to ASTM C494, Type A and Type F. Water reducing admixture shall not reduce durability, shall increase strength 10%, and shall not affect bleeding characteristics over reference mix.
- B. Air-Entraining Admixture shall be equal to MB AE90 Standard by BASF Admixtures, Inc., Darex by Grace Construction Products, or equal. Air-entraining admixture shall conform to ASTM C260.
- C. No other admixture will be allowed without written approval of the City. All admixture shall be compatible with cement, aggregate, and water used.

2.06 PROPORTIONING

- A. The proportions of aggregate to cement shall be such as to produce a workable mixture which can be thoroughly compacted and which will work readily in the forms and around reinforcement without permitting materials to segregate or excess water to collect on the surfaces. The combined aggregates shall be such that when separated on the No. 4 sieve, the weight passing the sieve shall not be less than 30% nor greater than 50%.
- B. Concrete of various classes shall have the following maximum water/cement or water/(cement + fly ash) ratio minimum compressive strengths at 28 days and minimum cement and fly ash contents:

Class	Maximum Water/Cement or Water/(Cement + Fly Ash)	Minimum 28 Day Strength-Pounds per Square Inch	Cement Content-Pounds per Cubic Yard	Fly Ash-Pounds per Cubic Yard	
				Type C	Type F
A	0.45	4.00	564	---	---
A-FA	0.45	4.00	480	110	125
B	0.53	3.5	517	---	---
C	0.53	3.0	517	---	---
X	---	2.0	376	---	---

- C. Except as indicated by the City, all concrete shall be Class A or Class A-FA concrete.
- D. All concrete mixes shall be designed for a strength of 15% above that specified to allow for job variations. All mixes shall be designed in accordance with ACI 211.1 by a competent concrete engineer or competent laboratory technician.
- E. The slump for all concrete, before addition of the water-reducing admixture, shall be 3 inches and concrete with a slump within the range of 2 to 3 1/2 inches will be acceptable unless otherwise stated.
- F. A water-reducing admixture shall be used in all concrete. A qualified representative of the manufacturer shall be available to assist in proportioning the concrete, advise on the proper addition of the admixture to the concrete, and advise on adjustments of concrete proportions to suit job conditions.
- G. An air-entraining admixture shall be used in all concrete except at patches. Air content shall be tested by the pressure method as outlined in ASTM C231 and shall be between four to seven percent by volume.
- H. Contractor shall submit to the City compressive strength of concrete cylinder test results for the same concrete mixes proposed on a previous project. If this information is not available, one cubic yard trial batches of each individual mix proposed for use shall be made prior to use in the work. Four test cylinders shall be made for each trial batch, two to be tested at 7 days and two at 28 days. The trial batches shall be made preceding actual placement operations so that the results of the 7-day tests can be obtained.
- I. All aggregates shall be measured by weight. The concrete mixer is to be equipped with an automatic water-measuring device which can be adjusted to deliver the desired amount of water.

2.07 WATERSTOPS

- A. PVC waterstops shall be as manufactured by Greenstreak, Inc., W.R. Meadows, Grace Construction Products, or equal. Provide serrated centerbulb-type, non-tapered 3/8-inch minimum thickness waterstops manufactured from virgin polyvinyl chloride with no reclaimed/scrapped material or pigment whatsoever conforming to Corps of Engineers CRD-C-572. The waterstop shall have an

integral fastening system consisting of hogrings or grommets. For 6-inch PVC waterstops in construction joints, use Greenstreak, Inc. Profile No. 732 or equal. For expansion joints, use Greenstreak, Inc. Profile No. 735 or equal. Where 4-inch PVC waterstops are called for in the drawings, use Greenstreak, Inc. Profile No. 702, or equal.

- B. Hydrophilic waterstop shall be a flexible hydrophilic natural rubber strip composed of non-vulcanized rubber and urethane polymer hydrophilic agent creating a moisture-activated, self healing waterproofing compound.
- C. Hydrophilic waterstop shall be Adeka Ultraseal, or equal, products as follows:
 - 1. Construction Joints:
 - a. Wall/slab thickness greater than 9 inches with double mat of reinforcing: MC-2010MN (3/4 inch by 3/8 inch) with embedded stainless steel wire mesh for expansion control. The waterstop shall develop a minimum of 400 psi expansion pressure and withstand a minimum 150-foot hydrostatic head. Expansion amount shall not exceed 120%.
 - b. Wall/slab thickness between 4 inches and 9 inches with 1-inch minimum cover and single or double mat of reinforcing: KBA-1510FP (9/16 inch by 3/8 inch). Expansion amount shall not exceed 30%.
 - 2. Pipe Penetrations:
 - a. Wall/slab thickness between 4 inches and 9 inches and pipe diameter greater than 4 inches and less than or equal to 24 inches: KBA-1510FP (9/16 inch by 3/8 inch).
 - b. Wall/slab thickness greater than 9" and pipe diameter greater than 4" and less than or equal to 24 inches: MC-2005T (3/4 inch by 3/16 inch).
 - c. Wall/slab thickness greater than 9 inches and pipe diameter greater than 24 inches: MC-2010MN (3/4 inch by 3/8 inch) with embedded stainless steel wire mesh for expansion control.

2.08 JOINT FILLER

- A. Expansion joints shall have standard 1/2-inch-thick cork expansion joint filler; W. R. Meadows or equal; meeting ASTM D1752–Type II. Exceptions to this are expansion joints in exterior concrete walks and between concrete walks and other structures which shall be asphalt expansion joint filler, 1/2-inch-thick; Grace, W.R. Meadows, or equal; meeting ASTM D994.

2.09 BONDING AGENT

- A. Acceptable manufacturers include Thorobond by BASF, Emaco P24 by BASF, or equal.

2.10 PATCHING ADDITIVE

- A. Acceptable manufacturers include ACRYL 60 by Harris Specialty Chemicals, Inc., Sonocrete by Sonneborn Contech Co., or equal.

2.11 NONSHRINK GROUT

- A. Acceptable manufacturers include Dayton Superior, Master Builders, or equal. Grout shall be nonshrink, nonmetallic and shall achieve a strength of 7,500 psi in 28 days.

2.12 CURE-SEAL-HARDENER

- A. Penetrating sealer for interior building floors shall be Ashford Formula by Curecrete Chemical Company, Inc., or equal. See finish schedule for locations to be used.

PART 3-EXECUTION

3.01 MIXING

- A. Ready-mixed concrete shall be batched, mixed, and delivered in accordance with ASTM C94 and ACI 304 from an approved batching plant. In general, concrete shall be mixed 50 revolutions at plant, 20 upon arrival at site, and 20 each time water is added; maximum of 110 revolutions at mixing speed. Concrete shall be delivered and discharged within 1 1/2 hours or before the drum has revolved 300 times after introduction of water to the cement and aggregates or the cement to the aggregates. Truck mixers shall be equipped with drum revolution counters. In no event shall concrete which has taken its initial set be allowed to be used. Retempering of concrete is not permitted.
- B. No water shall be added on the job.
- C. Concrete shall have a temperature not less than 60°F nor more than 80°F as delivered to the job site.
- D. With each load of concrete Contractor shall obtain delivery tickets and shall make these tickets available for review by the City. Delivery tickets shall provide the following information:
 - 1. Date.
 - 2. Name of ready-mix concrete plant, job location, and Contractor.
 - 3. Type of cement and admixtures, if any.
 - 4. Specified cement content in sacks per cubic yard of concrete and approved concrete mix number or designation.
 - 5. Amount of concrete in load, in cubic yards.

6. Water added at job, if any.
 7. Truck number and time dispatched.
 8. Number of mixing drum revolutions.
- E. For job mixed concrete, all concrete materials shall be mixed in a machine batch mixer for at least 1 1/2 minutes after all ingredients are in the mixer and shall continue until there is a uniform distribution of the materials, and the mass is uniform in color and homogeneous. The mixer shall not be loaded beyond the capacity given by the manufacturer and shall be rotated at the speed recommended by the manufacturer. The mixer is to be provided with positive timing device which will positively prevent discharging the mixture until the specified mixing time has elapsed.

3.02 JOINTS

- A. Contractor shall place all joints as specified herein. If all joints shall be straight, truly vertical or horizontal, and proper methods shall be employed to obtain this result.
- B. Contractor shall provide joints as follows:
1. Walls shall have vertical joints at 30 feet on center maximum but not more than 15 feet from corners or intersections and shall have horizontal joints at 15 feet on center maximum.
 2. Slabs shall have joints at 20 feet on center maximum in each direction.
- C. Immediately after completion of the first pour at a joint, the concrete surface, reinforcement, and waterstop projecting beyond the joint shall be thoroughly cleaned and laitance removed. The waterstops shall not be disturbed after the concrete in the first pour at a joint has set. Concrete around waterstops shall be thoroughly compacted by hand spading and vibrating. Immediately before the second pour, all extraneous matter shall be removed from the joint, the waterstop and steel cleaned, and the surface thoroughly wetted.
- D. Concrete at all joints shall have been in place at least 48 hours before abutting concrete is placed. At least two hours must elapse after depositing concrete in columns or walls before depositing in beams, girders, or slab supported thereon. Beams, girders, brackets, column capital, and haunches shall be considered as part of the floor system and shall be placed integrally therewith.

3.03 WATERSTOPS

- A. Unless noted otherwise, PVC waterstops shall be provided at all expansion joints and at construction joints in floors and walls of structures exposed to ground or liquid on one side and occupied by personnel or nonsubmerged equipment on the other side.

- B. PVC waterstops shall be made continuous by splicing. Waterstops shall be spliced using a corner, tee, or cross splice, as applicable, at intersections. Waterstops shall be mitered to maintain the continuity of the ribs and center bulb. Splices shall be made using a hot metal plate or an electric splicer and full butt weld. Direct flame will not be allowed.
- C. PVC waterstops placed in all joints shall be securely held in place by an approved method. PVC waterstops shall be installed and secured prior to concrete placement. PVC waterstops shall not be inserted into wet concrete. No nails will be permitted through the waterstop. Great care shall be taken when concrete is placed to insure that the waterstop remains erect and is not bent over.
- D. Unless noted otherwise, hydrophilic waterstop shall be provided at all construction joints in liquid holding tanks and channels which are not adjacent to areas occupied by personnel and at joints between new and existing concrete. Waterstop shall be placed in accordance with the manufacturer's recommendations.

3.04 BONDING TO EXISTING CONCRETE

- A. When placing new concrete adjacent to existing concrete, the existing concrete shall be thoroughly roughened, cleaned, and saturated with water 24 hours before pouring new concrete. Existing concrete is defined as concrete more than six months old. At time of new pour, remove any standing water and apply bonding agent. Bonding agent shall be applied in accordance with manufacturer's recommendations.
- B. When patching existing concrete, remove poor concrete until firm hard concrete is exposed; roughen and clean surface of the existing concrete, clean any exposed reinforcing bars, and pour new concrete. Concrete finish to match existing concrete. New concrete shall be 4,000 psi 28-day strength mixed with patching additive, mixed according to manufacturer's instructions. Concrete shall not be air-entrained.

3.05 EMBEDDED ITEMS IN CONCRETE

- A. All sleeves, inserts, anchors, and embedded items required for adjoining work or for its support shall be placed prior to concreting.
- B. All Contractors whose work is related to the concrete or must be supported by it shall be given ample notice and opportunity to introduce and/or furnish embedded items before the concrete is placed.
- C. Embedded items shall be positioned accurately and supported against displacement. Reinforcing bars shall clear embedded items a minimum of 2 inches.

3.06 PLACING CONCRETE

- A. Before placing concrete, all equipment, forms, ground, reinforcements, and other surfaces with which the concrete will come in contact are to be thoroughly cleaned of all debris, ice, and water. Ground shall be wetted prior to placement of concrete on it.
- B. Concrete shall be conveyed from the mixer to the place of final deposit as rapidly as practicable by methods which will prevent the segregation or loss of materials. Chuting concrete directly into the form will not be allowed. Chuting for conveying purposes will be allowed only upon approval by the City and must be accomplished in such a manner as to prevent segregation or loss of materials. Receiving hoppers shall be installed at the chute discharge and at no point in its travel from the mixer to place of final deposit shall the concrete pass through a free vertical drop of more than 3 feet. Elephant trunks or tremies shall be used in all wall pours to prevent coating of forms and reinforcing bars.
- C. Care shall be taken to avoid an excess of water on the concrete surface. Excess water shall be drained or otherwise removed from the surface. Dry cement or a mixture of cement and sand shall not be sprinkled directly on the surface to absorb water.
- D. Concrete in wall and beam pours shall be deposited in approximately horizontal layers not to exceed 18 inches in thickness. Each layer shall be well worked into the preceding layer while both layers are still soft.
- E. Concrete shall be deposited as nearly as practicable in its final position to avoid segregation due to rehandling or flowing. The maximum allowable lateral movement of the concrete after being deposited is 3 feet. When concreting is once started, it shall be carried on as a continuous operation until the placing of the section or panel is completed.
- F. All concrete shall be placed with the aid of mechanical vibrating equipment in accordance with ACI 309. In congested areas vibration shall be supplemented by hand spading adjacent to the forms. Vibration should secure the desired results within 5 to 15 seconds at intervals of 18 inches apart maximum. The vibrator shall penetrate the preceding layer of concrete. Vibrators shall have a frequency of not less than 10,000 impulses per minute when in operation submerged in concrete.
- G. A sufficient number of spare vibrators shall be kept in ready reserve to assure adequate vibration in case of breakdown of those in use.
- H. In placing concrete in beams where it is intended to be continuous and monolithic with the slab above, a delay to provide for settlement of the deep concrete shall be scheduled before placing the upper concrete in the slab. The length of delay shall be as long as possible and still permit the revibration of the deep concrete.
- I. Concrete is not to be placed under water. A suitable means shall be provided for lowering the water level below surfaces upon which concrete is to be placed.

This may require excavating approximately 12 inches below the bottom of the concrete surface and refilling with gravel and compacting. The groundwater shall not be allowed to rise to the bottom of the concrete until 24 hours after the concrete pour has been completed. Water shall not be allowed to fall upon or run across the concrete during this period.

3.07 MOIST CURING

- A. All concrete shall be maintained in a moist condition for at least 7 days after being deposited except that for high-early strength concrete, a 3-day period will be sufficient. Moist curing shall be accomplished by one of the following methods:
1. Wood forms left in place and kept wet at all times. If the forms are not going to be kept wet, they shall be removed as soon as practicable and other methods of moist curing shall be started without delay.
 2. Use of a curing compound conforming to ASTM C309, Type I. Curing compound shall be applied at a uniform rate as indicated by the manufacturer sufficient to comply with the requirements of the test water retention of ASTM C156. Curing compound applied to vertical concrete surfaces after forms are removed shall be specially adapted to provide required coverage on the vertical surface. On nonformed surfaces, the curing compound shall be applied immediately after the disappearance of the water sheen after finishing of the concrete. Curing compound shall not be used on concrete surfaces which are to be painted, receive ceramic tile or resilient flooring, or be waterproofed unless approved by the City. Care shall be taken not to get curing compound on construction joints, reinforcing steel, and other surfaces against which new concrete will be poured.
 3. Use of plastic film. Plastic film shall have a minimum thickness of 4 mils. It shall be placed over the wet surface of the fresh concrete as soon as possible without marring the surface and shall be weighted so that it remains in contact with all exposed surfaces of the concrete. All joints and edges shall be lapped and weighted. Any tears in the film shall be immediately repaired.
 4. Application of wet coverings weighing 9 ounces per square yard such as burlap, cotton mats, or other moisture-retaining fabrics. The covering system shall include two layers and shall be kept continuously moist so that a film of water remains on the concrete surface throughout the curing period.
 5. Use of an approved waterproof curing paper. Edges of adjacent sheets shall be overlapped several inches and tightly sealed.
 6. Ponding of water or continuous sprinkling of water is permitted. Sprinkling at intervals will not be permitted.

7. Construction joints shall be moist cured by one of the methods listed above except by Method "2."
- B. The use of moist earth, sand, hay, or another method that may discolor hardened concrete will not be permitted.

3.08 HOT WEATHER CONCRETING

- A. When the atmospheric temperature exceeds 80°F during concrete placement, this section and ACI 305 shall apply in addition to all other sections of the specifications.
- B. The temperature of the delivered concrete shall not exceed 85°F.
- C. Care shall be exercised to keep mixing time and elapsed time between mixing and placement at a minimum. Ready-mix trucks shall be dispatched so as to avoid delay in concrete placement, and the work shall be organized to use the concrete promptly after arrival at the job site.
- D. The subgrade, forms, and reinforcing shall be sprinkled with cool water just prior to placement of concrete. Prior to placing concrete, there shall be no standing water or puddles on the subgrade.
- E. If approved by the City, an admixture for retarding the setting of the concrete may be used.
- F. Exposed concrete surfaces shall be carefully protected from drying. Continuous water curing is preferred. Curing compounds shall be white pigmented.

3.09 COLD WEATHER CONCRETING

- A. Conditions of this section shall apply, in addition to all other sections of the specifications, when placing concrete in cold weather. Cold weather is defined as a period when, for more than three successive days, the average daily temperature drops below 40°F. When temperatures above 50°F occur during more than half of any 24-hour period, the period will no longer be regarded as cold weather. The average daily temperature is the average of the highest and lowest temperature during the period from midnight to midnight. Cold weather concreting shall conform to all requirements of ACI 306.1, Standard Specification for Cold Weather Concreting, published by the American Concrete Institute, Detroit, Michigan, except as modified by the requirements of these specifications.
- B. Detailed procedures for the production, transportation, placement, protection, curing, and temperature monitoring of concrete during cold weather shall be submitted to the City. Cold weather concreting shall not begin until these procedures have been accepted.
- C. All concrete materials, forms, ground, mixing equipment, and other surfaces with which the concrete is to come in contact shall be free from frost, and the temperature of contact surfaces shall be 35°F or above. Ground upon which concrete is to be placed shall not be frozen at any depth.

- D. The mixing water and aggregates shall be heated and when entering the mixer shall have temperatures not exceeding 175°F and 80°F, respectively. Concrete temperature as mixed shall not exceed 80°F and shall typically be between 55°F and 70°F. Concrete, when placed in the forms, shall have a temperature of not less than 50°F.
- E. Freshly placed concrete shall be protected by adequate covering, insulating, or housing and heating. If heating is used, ambient temperature inside the housing shall be maintained at a minimum of 70°F for 3 days or 50°F for 5 days. The maximum ambient temperature during curing shall not exceed 80°F. If insulating methods are used, recommendations contained in ACI 306R-78 shall be followed. Surface temperature shall be maintained at 50°F for 7 days. After the curing period, the temperature of the concrete shall be reduced uniformly at a rate not to exceed 40°F per 24 hours until outside air temperature is reached. Heating of enclosure shall continue if it is anticipated that the outside air temperature will drop more than 20°F in the next 24 hours. The concrete temperature shall be obtained by attaching a thermometer provided by Contractor to the concrete surface. Concrete shall be kept moist.
- F. If heating is used, the housing shall be constructed weather-tight and shall be constructed in a manner that will provide uniform air circulation and air temperatures over the complete concrete area that is being cured. Special attention shall be given to the edges and ends of a concrete pour with the housing extending at least 5 feet beyond any concrete surface being protected. The housing shall be in place and heat applied within two hours after concrete placement.
- G. Heating may be by steam or hot air. Heaters shall be vented to outside of the housing. Open burning salamanders will not be permitted. Heating devices shall not be placed so close to the concrete as to cause rapid drying or discoloration from smoke.
- H. If heating is used, Contractor shall provide sufficient 24-hour inspection of the heaters to insure compliance with the above-specified temperature requirements during the curing period.
- I. The use of calcium chloride, salts, or other chemical admixtures for the prevention of freezing is prohibited.
- J. Salts or other deleterious materials shall not be used on temporary or permanent structures above concrete surfaces that are being placed, finished, or cured.

3.10 FINISHING

- A. Flat Work:
 - 1. Floated Finish: Place, consolidate, strike off, and level concrete eliminating high spots and low spots. Do not work concrete further until it is ready for floating. Begin floating with a hand float, a bladed power float equipped with float shoes, or a powered disk float when the bleed water

sheen has disappeared and the surface has stiffened sufficiently to permit the operation. Immediately refloat the slab to a uniform texture.

2. Light Troweled Finish: Float concrete surface, then power trowel the surface. Hand trowel the surface smooth and free of trowel marks.
3. Hard Troweled Finish: Float concrete surface, then power trowel the surface. Hand trowel the surface smooth and free of trowel marks. Continue hand troweling until a ringing sound is produced as the floor is troweled.
4. Tolerance for concrete floors shall be 1/4-inch within 10 feet in any direction. Straight edge shall be furnished by Contractor.
5. Broom or Belt Finish: Immediately after concrete has received a floated finish, give the concrete surface a coarse transverse scored texture by drawing a broom or burlap belt across the surface.
6. The above finishes shall be used in the following locations:
 - a. Float Finish: Surface to receive roofing, waterproofing, or sand bed terrazzo.
 - b. Light Troweled Finish: Submerged tank slabs.
 - c. Hard Troweled Finish: Building floors.
 - d. Broom or Belt Finish: Exterior slabs, drives, sidewalks, tops of walls, and tank slabs to receive grout topping.

B. Formed Surfaces:

1. Within two days after removing forms and prior to application of a curing compound, all concrete surfaces shall be observed and any poor joints, voids, stone pockets, or other defective areas shall be patched at once before the concrete is thoroughly dry. Defective areas shall be chipped away to remove all loose and partially bonded aggregate. The area shall be thoroughly wetted and filled with as dry as practical mortar mix placed to slightly overfill the recess. Mortar shall include a bonding agent. After partial set has taken place, the excess mortar shall be removed flush with the surface on the concrete using a wood float. All patching shall be cured, protected, and covered as specified for concrete. All cracks, leaks, or moist spots which appear shall be repaired.
2. The exterior or removal portion of nonremovable ties shall be removed with the use of a special tool designed for this purpose. Cutting or chipping of concrete to permit removal of exterior portion will not be permitted.
3. For nonremovable ties, tie rod holes left by the removal of the exterior portion of the tie and cone shall be thoroughly wetted and filled by

ramming with as dry as practical mortar mix in such a manner as to insure complete filling of the hole. Mortar shall include a bonding agent. All patching shall be cured, protected, and covered as specified for concrete. The holes are to be filled immediately after removal of the exterior portion of the tie.

4. Holes left by removable ties shall be filled by installing a neoprene plug near the center of the wall. The balance of the hole shall be filled with mortar as specified above to within 1 inch of the face of the wall. The remainder of the hole shall be filled with a waterproofing compound.
5. All finished or formed surfaces shall conform accurately to the shape, alignment, grades, and sections as shown or prescribed by the City. All surfaces shall be free from fins, bulges, ridges, offsets, honeycombing, or roughness. All sharp angles, where required, shall be rounded or beveled. Any formed surface to be painted shall be free of any material that will be detrimental to the paint. The surface of the concrete shall be given one of the following finishes immediately after form stripping:
 - a. Finish A shall be referred to as a sack finish. Surfaces shall be free of contaminants prior to sacking. After wetting the surface, a grout shall be rubbed in using a rubber float or burlap. After the grout hardens sufficiently, it shall be scraped from the surface with the edge of a steel trowel without disturbing the grout in the air holes. After further drying, the surface shall be rubbed with burlap to remove all surface grout. The entire surface shall be finished to secure a continuous, hard, dust-free and uniform texture surface free from pinholes and other minor imperfections. Finish A will be required for all painted surfaces, interior surfaces of equipment rooms, operation areas, and permanently exposed vertical surfaces. Where steel faced forms are used to form walls, the portion of wall to receive the sack finish shall first be roughened by brush blasting or other approved method to achieve a texture similar to 40-60 grit sandpaper.
 - b. Finish B shall be the same as Finish A, except that the final burlap rubbing may be omitted, providing the steel trowel scraping removes the loose buildup from the surface. Finish B shall be provided for waterproof and moistureproof coated surfaces.
 - c. Finish C shall be referred to as a finish which has surface imperfections less than 3/8-inch in any dimension. Surface imperfections greater than 3/8-inch shall be repaired or removed and the affected areas neatly patched. Finish C or smoother shall be provided for interior surfaces of wet wells, tanks, and channels from 1 foot below minimum water surfaces and down and otherwise unfinished interior surfaces.
 - d. Finish D shall be the finish for surfaces which may be left as they come from the forms, except that tie holes shall be plugged and defects greater than 1/2-inch in any dimension shall be repaired.

Finish D shall be provided for surfaces to be buried or covered by other construction such as masonry veneer.

- C. All precautions shall be taken to protect the concrete from stains or abrasions.

3.11 LOADING OF CONCRETE STRUCTURES

- A. No concrete structure or portion thereof shall be loaded with its design load until the concrete has obtained its specified 28-day compressive strength. This shall include but not be limited to vertical live load, equipment loading, water loading, groundwater loading, and backfill load. Concrete strength at time of loading shall be determined by testing field-cured concrete cylinders.
- B. Extreme care shall be taken to insure that construction loads do not exceed design loading of the structure.

3.12 WATER TEST

- A. When requested by the City, liquid-retaining structures shall be water tested by Contractor before being faced with masonry or backfilled. Generally, concrete structures separating liquid from occupied spaces and above grade tanks with veneer cladding or exposed to weather shall be tested. The structure shall be filled with water, kept full for at least 24 hours, leaks or moist areas marked, and the structure or surrounding area drained. Repairs shall be made from the face of the concrete which is subjected to water pressure.
- B. Testing of the structure shall not take place until the last concrete placed in the structure has developed 28-day design strength as determined by testing field-cured concrete cylinders.
- C. After repair, the structure shall again be tested as above. Testing and repair shall continue until all leaks or moist spots have disappeared.

3.13 NONSHRINK GROUT

- A. Nonshrink, nonmetallic grout shall be used for filling recesses and pockets left for equipment installation and for setting of base plates. Store, mix, and place the nonshrinking compound as recommended by the manufacturer. The minimum compressive strength shall be 5,000 psi at age 7 days and 7,500 psi at age 28 days.

3.14 TESTING AND SAMPLING

- A. For concrete pours greater than 10 yards, the following tests of fresh concrete shall be performed by Contractor. Contractor shall prepare, protect, transport, and have tested all cylinders at his expense.
 - 1. Sampling of concrete for slump tests, air tests, temperature tests, and for making concrete test cylinders shall be performed in accordance with ASTM C172.

2. Cylinders:
 - a. Three test cylinders shall be made for each pour less than 25 cubic yards, 4 test cylinders shall be made for each pour between 25 and 100 cubic yards, and 8 test cylinders made for each pour in excess of 100 cubic yards. Each concrete mix shall be represented by at least 4 cylinders for the entire job. Concrete for cylinders shall be collected near the middle of the load.
 - b. Cylinders shall be made and tested in accordance with ASTM C31 and ASTM C39, respectively. The cylinders must be kept moist and at temperatures between 60°F and 80°F and shall remain undisturbed and stored in a location free from vibration. In hot weather, the cylinders shall be covered with wet burlap and stored in a shaded area. It is Contractor's responsibility to provide a suitable protected location for storing cylinders on the job site.
 - c. After 24 hours, the cylinders shall be transferred to an independent testing laboratory acceptable to the City. The cylinders shall be packed in sawdust or other cushioning material for transit to avoid any bumping or jarring of the cylinders.
 - d. Cylinders shall be broken at 7 and 28 days. Test data shall include date and location of pour and concrete mix used.
3. Slump Test: Contractor shall make one slump test near the beginning of all pours with two tests being made for all pours in excess of 25 yards. Slump tests shall conform to ASTM C143.
4. Air Test:
 - a. When air-entrained concrete is used, the air content shall be checked by Contractor near the beginning of all pours with at least two checks being made for all pours in excess of 25 cubic yards.
 - b. The air contents shall be checked using the pressure method in accordance with ASTM C231. The pocket-sized alcohol air indicator shall not be used unless it is first used in conjunction with the pressure method test.

3.15 RECORDS

- A. If required by the City, records are to be kept of all concrete work. The record shall include the date, location of pour, concrete mix, slump, air content, test cylinder identification, concrete temperature, and ambient air temperature. In addition, for cold weather concreting, the record shall include the daily maximum-minimum thermometer readings of all thermometers during the entire curing period for all concrete pours. Contractor shall provide a copy of the records to the City.

3.16 CURING AND SEALING INTERIOR BUILDING FLOORS

- A. Install cure-seal-hardener product in accordance with manufacturer's instructions. Apply only to those floors noted to be sealed in the finish schedule.
- B. Where product will be used for moist curing, sealing and hardening, apply to new concrete as soon as the concrete is firm enough to walk on after troweling. Where product will be used for sealing and hardening only, surface must be free of dust, dirt, laitance, curing compounds, and any material that would inhibit the penetration of the product. In some instances, the floor may need to be stripped and neutralized prior to application.
- C. Spray on at rate of 200 square feet per gallon.
- D. Keep surfaces wet with cure-seal-hardener for minimum soak-in period of 30 minutes, without allowing drying out or becoming slippery. In hot weather, slipperiness may appear before the 30-minute time period has elapsed. If that occurs, apply more cure-seal-hardener as required to keep entire surface in a non-slippery state for the first 15 minutes. For the remaining 15 minutes, mist the surface as needed with water to keep the material in a non-slippery state.
- E. After this period, when treated surface becomes slippery, lightly mist with water until slipperiness disappears.
- F. Wait for surface to become slippery again and then flush entire surface with water removing all residue of cure-seal-hardener.
- G. Squeegee surface completely dry, flushing any remaining slippery areas until no residue remains.
- H. Wet vacuum or scrubbing machines may be used to remove residue, provided manufacturer's instructions are followed.
- I. Protect installed floors until chemical reaction process is complete; at least three months.
- J. Clean up spills immediately and spot-treat stains with good degreaser or oil emulsifier.
- K. Protection and cleaning of floors are the responsibility of Contractor until final completion. Replace concrete that becomes stained due to improper precautions or lack of cleaning.

END OF SECTION

SECTION 8

BURIED PIPING, MANHOLES AND APPURTENANCES

PART 1-GENERAL

1.01 SUMMARY

A. Work Included:

1. All underground piping, manholes and appurtenance except as specified in Section 9.

1.02 REFERENCES

- A. Standard Specifications: Unless otherwise indicated, Standard Specifications within this section shall refer to the Indiana Department of Transportation Standard Specifications.
- B. Ten State Standards.

PART 2-PRODUCTS

2.01 MATERIALS OF CONSTRUCTION

- A. All materials used in the manufacture, assembly, and painting of piping and valves in contact with water shall be compatible with potable water supplies and in contact with chemical feed systems shall be compatible with the chemicals being used. All glues, solvents, solders, etc., shall likewise be compatible. For instance, no lead-base solders shall be used. All materials in contact with water to be used for potable water supplies shall be National Sanitation Foundation (NSF)-approved.
- B. In joining two dissimilar types of pipe, standard fittings shall be used when available.
- C. Piping appurtenances shall be made of the materials specified.

2.02 APRON ENDWALLS

- A. Concrete apron endwalls for concrete pipe sewers shall be manufactured with reinforcement and concrete conforming to the pertinent requirements for minimum Class II, Wall B, reinforced concrete pipe as specified in ASTM C 76. Concrete apron endwalls for concrete elliptical pipe sewers shall be manufactured with reinforcement and concrete conforming to the pertinent requirements for Class HE-III reinforced concrete elliptical pipe as specified in ASTM C 507.

2.03 SANITARY MANHOLES

- A. Unless otherwise specified by the City, all manhole sections including risers, flat slab tops, conical tops, base sections, and adjusting rings shall be precast reinforced concrete. Reinforced concrete manhole sections shall conform to ASTM C478
- B. Precast, reinforced concrete manhole bases, riser sections, flat slabs and other components shall be manufactured by wet cast methods only, using forms which will provide smooth surfaces free from irregularities, honeycombing or other imperfections.
- C. Lengths of manhole riser (barrel) shall be furnished in such combinations as to conveniently make up the depth of the manhole. A maximum of two handling holes per length of riser will be permitted.
- D. Standard sewer manholes shall be constructed with eccentric cone top section for 48-inch-diameter barrel sections. For other diameters the top section shall be a cone section, if available, or flat slab. Flat slabs shall have opening offset. Concrete adjusting rings shall be furnished to set the manhole casting to established grade.
- F. Drop entrances to sanitary sewer manholes shall be installed where required. Drop entrances shall be of the same diameter as the sewer main from sizes 8 inch through 18 inch. For larger diameters, the drop shall be 18 inches unless otherwise specified by the City. Drop entrances for storm sewer manholes are not required.
- G. The interior bottom of sanitary sewer and storm sewer manholes shall be constructed of concrete benches which shall be precast or poured-in-place in the field. Benches shall extend to the top of each pipe to a maximum height of 42 inches. Flow lines shall be made smooth with uniform curves to promote flow through the manhole.
- H. All joints between manhole pipe sections and top shall be tongue and groove conforming to ASTM C443. Manhole joints shall be sealed with circular O-ring conforming to ASTM C443 or bituminous jointing material equal to EZ-Stick, Kent Seal, Ram-Nek, or Mas-Stik butyl rubber gasket, or butyl rubber rope.
- I. Manhole connections for sanitary sewer mains shall be made using flexible, watertight connections, PSX Press Seal, Kor-N-Seal, or equal, for sewers up through 18-inch-diameter. All other sanitary sewer manhole connections shall be made with A-Lok, PSX Press Seal, Kor-N-Seal, or equal. Manhole connections for all other piping shall be made with A-Lok, PSX Press Seal, Kor-N-Seal, or concrete grout.
- J. Manhole bottoms for sanitary sewer shall be monolithically precast with the bottom section for manholes up through 6-foot-diameter. Bottoms for larger diameter manholes shall be precast but need not be monolithically cast with the

bottom section. All other manhole bottoms shall be either poured-in-place or precast concrete.

- K. Manholes shall be furnished large enough to provide a minimum distance, between adjacent pipe, measured tangentially along the inside face of the manhole, equal to one-half the outside diameter of the intersecting sewer pipe. In any event, manholes shall be furnished in the diameter necessary to accommodate intersecting sewer pipe and the pipe to manhole connection as proposed for use.
- L. Precast reinforced concrete manhole risers and tops shall be tested in accordance with ASTM C497. Precast reinforced concrete manhole risers and tops meeting the strength requirements will be considered acceptable and shall be stamped with an appropriate monogram. When requested, copies of test reports shall be submitted to the City before the manhole sections are installed in the Project. Final acceptance will be made after field inspection upon delivery to the job site.
- M. Precast reinforced concrete manhole sections shall be subject to rejection for failure to conform to any of the Specification requirements. In addition, individual sections of manhole risers and tops may be rejected because of any of the following reasons:
 - 1. Fracture or cracks passing through the wall, except for a single end crack that does not exceed the depth of the joint.
 - 2. Defects that indicate imperfect proportioning, mixing, and molding.
 - 3. Surface defects indicating honey-combed or open texture.
 - 4. Damaged ends, where such damage would prevent making a satisfactory joint.
 - 5. Noticeable infiltration into manhole.
 - 6. Variation in diameter of the manhole section of more than 1 percent from the nominal diameter.
 - 7. Any continuous crack having a surface width of 0.01 inch or more and extending for a length of 12 inches or more regardless of position in the section wall.
- N. Each precast reinforced concrete manhole riser and top section shall be clearly marked with the name or trademark of the manufacturer and the date of manufacture. This marking shall be indented into the manhole section or shall be painted thereon with waterproof paint.
- O. Precast concrete adjusting rings for standard manholes shall have an inside diameter of 26 inches, be not less than 2 inches nor more than 6 inches high,

and shall have a wall thickness of 6 inches unless otherwise specified. The rings shall contain a minimum of one No. 2 reinforcing rod centered within the ring.

P. Frames and Covers: for standard sanitary manholes, frames shall be East Jordan Iron Works 1037Z, 1050Z1, or equal.

Q. Manhole Chimney Seals

1. External manhole chimney seals shall be provided for all new manholes. Chimney seal shall be Cretex, or equal.
2. Existing manholes exposed during the construction period shall have the adjustment rings replaced and a new chimney seal installed. Existing castings shall be reused.

2.04 STORM SEWER INLETS, CATCH BASINS AND MANHOLES

A. All storm sewer inlets, catch basins and manholes shall be precast concrete structures meeting the requirements of ASTM C913 and Section 720 of the INDOT Specifications.

B. Castings shall conform to the requirements of Section 910 of the INDOT Specifications.

2.05 BURIED PIPING

A. DUCTILE IRON PIPING AND FITTINGS:

1. Except as otherwise specified, underground pipe shall have mechanical joints or push-on joints conforming to AWWA C110 and C111 with vulcanized styrene butadiene rubber gaskets conforming to AWWA C111. Gaskets that include metal locking segments vulcanized into the gasket to grip the pipe and provide joint restraint are not acceptable. Bolts on exterior joints shall be high-strength low-alloy steel (Corten, or equal) conforming to AWWA C111. Certificate to that effect shall be provided.
2. Restrained joints shall be provided in accordance with PART 3-EXECUTION. Mechanical joints shall be restrained with MEGALUG® Series 1100 or 1100SD, by EBAA Iron Sales, Inc., UNIFLANGE Series 1400 by Ford Meter Box Co., Inc., or equal, restraint. Push-on joints for ductile iron piping shall be restrained with MEGALUG®, Series 1100HD or 1700, by EBAA Iron Sales, Inc., UNIFLANGE Series 1450 by Ford Meter Box Co., Inc., Flex-Ring or Lok-Ring by American Cast Iron Pipe Company, TR Flex by U.S. Pipe Company, or equal.
3. Joint restraint is not required for gravity sewers.
4. Underground pipe shall have mechanical joint or push-on joint ductile iron fittings conforming to AWWA C110 and C111 or AWWA C153 compact fittings with a minimum rated working pressure of 150 psi. Gaskets for fittings shall be as specified for underground piping.

5. All ductile iron fittings shall be American, Clow, Griffin, Tyler, U.S. Pipe, or equal.
6. Unless otherwise specified, all ductile iron fittings shall be cement-mortar-lined and asphaltic-coated inside. Unless otherwise specified, underground piping and fittings shall be asphaltic-coated outside. Cement-mortar lining shall be in accordance with AWWA C104. Asphaltic coating shall conform to applicable standards herein for the pipe and fittings.

B. REINFORCED CONCRETE PIPE FOR STORM SEWERS

1. Reinforced concrete pipe for storm sewer shall meet the requirements of ASTM C76 for circular pipe and ASTM C507 for elliptical pipe. Strength and class of the pipe shall conform to the drawings and as specified herein. All reinforced concrete pipe used in the work shall be of adequate strength to support the trench loads applied.
2. Standard and special fittings shall be of approved manufacture and shall conform to requirements of the trade and these specifications. All fittings shall be of a strength at least equal to that of the sewer main and shall be jointed with the same type of joint as used in the sewer main.
3. Not more than one lift hole per length of pipe shall be used in storm sewer.
4. Reinforced concrete pipe and fittings shall be joined with joints that meet the requirements of the ASTM C443. All pipe shall be specifically built to fit the gasket used. Gaskets for storm sewer shall be Tylox, or equal. Provide precast concrete endwalls on all storm sewers.

C HIGH DENSITY POLYETHYLENE PIPE FOR STORM SEWERS

1. Corrugated pipe composed of high density polyethylene shall meet the requirements of AASHTO M252 and M294. Pipe and fittings shall be made from virgin polyethylene compounds conforming to ASTM D3350.
2. Pipe shall have interior smooth inner wall of full circular cross section with an integrally formed outer corrugated wall AASHTO Type S design.
3. Fittings may be molded or fabricated and shall not impair the integrity or function of the pipe. Only fittings supplied or recommended by pipe manufacturer shall be used. Where elastomeric gaskets are required they shall conform to ASTM F477.

D. PVC PIPING:

1. Sanitary Sewer Piping:

- a. Polyvinyl Chloride (PVC) pipe shall meet the requirements of ASTM D3034 for pipe sizes 4 inches through 15 inches and ASTM F679 for pipe sizes 18 inches through 36 inches.
- b. PVC material for ASTM D3034 pipe shall have cell classification 12454-B or 12454-C as defined in ASTM D1784 with minimum modulus of elasticity of 400,000 psi. Pipe stiffness shall be minimum 46 psi when tested in accordance with ASTM D2412. Pipe shall have a maximum standard dimension ratio (SDR) of 35.
- c. PVC material for ASTM F679 pipe shall have cell classification 12454 or 12364 as defined in ASTM D1784 with a minimum modulus of elasticity of 500,000 psi. Pipe stiffness shall be a minimum 115 psi when tested in accordance with ASTM D2412.
- d. Pipe and fittings shall be the product of one manufacturer and the manufacturer shall have experience records substantiating acceptable performance of the pipe and fittings to be furnished. The minimum wall thickness of fittings shall be the same as the pipe to which it connects.
- e. Acceptance of piping and fittings shall be subject to tests conducted by an approved testing agency in accordance with ASTM D3034 and/or ASTM F679.
- f. Fittings such as saddles, elbows, tees, wyes, and others shall be of material and construction corresponding to and have a joint design compatible with the adjacent pipe. Approved adapters shall be provided for transitions to other types of pipe.
- g. Joints shall be of the elastomeric type for pipes 4 inches or larger and elastomeric or solvent cement for pipes less than 4 inches.
- h. Elastomeric joints shall be a bell and spigot joint conforming to ASTM D3212 sealed by a rubber gasket conforming to ASTM F477 so that the assembly will remain watertight under all conditions of service, including the movements resulting from the expansion, contraction, settlement, and deformation of the pipe. Bells shall be formed integrally with the pipe and shall contain a factory-installed positively restrained gasket.
- i. Solvent cement joints shall be assembled using solvent cement obtained from the pipe manufacturer, which conforms to the requirements of ASTM D2564.
- j. The assembled joint shall pass the performance tests as required in ASTM D3212.

2. Sanitary Force Main:

- a. Standard dimension ratio PVC pressure rated pipe shall conform to the requirements of ASTM D2241 (SDR-PR) for pipe from 4 inch through 12 inch. Pipe shall be furnished with integral elastomeric bell and spigot joints. Spigot end shall conform to ASTM D2241. Bell end shall conform to ASTM D3139. Gaskets shall meet ASTM F477.20000-12
- b. PVC pipe diameter shall conform to galvanized iron or steel pipe sizes (IPS). The type of PVC material, nominal pipe size, standard dimension ratio, and pressure rating shall be not less than pressure class 200 and not greater than standard dimension ratio (SDR) 21.
- c. Markings on the pipe shall include the following: Nominal pipe size, type of plastic pipe material, SDR number, pressure class rating, manufacturer's name, and the seal or mark of the laboratory making the evaluation of the suitability of the pipe for the transport of potable water.
- d. Fittings on PVC pipe shall be ductile iron mechanical joint conforming to requirements specified for ductile iron fittings with appropriate transition fittings and gaskets.
- e. Provide tracer wire and location/testing markers.
- f. Push-on joints for PVC piping shall be restrained with MEGALUG Series 1500 (AWWA C900) or Series 2800 (AWWA C905) by EBAA Iron Sales, Inc., UNIFLANGE SERIES 1350 by Ford Meter Box Co., Inc., or equal. PVC piping with ductile iron mechanical joint fittings shall be restrained with MEGALUG Series 2000 PV by EBBA Iron Sales Inc., UNIFLANGE Series 1500 by Ford Meter Box Co., Inc., or equal.

E. HIGH DENSITY POLYETHYLENE PRESSURE (HDPE) PIPE AND FITTINGS

1. HDPE pressure rated pipe for sanitary force main shall conform to the requirements of AWWA C906 for pipe from 4 inch through 63 inch. HDPE pipe shall be manufactured from material conforming to PE code PE3608.
2. HDPE pipe diameter shall conform to the O.D. of ductile iron pipe (DIOD). The type of HDPE material, nominal pipe size, standard dimension ratio, and pressure rating shall be not less than pressure class 200 and not greater than a dimension ratio (DR) 9.
3. Markings on the pipe shall include the following: Normal pipe size, type of plastic pipe material, DR number, pressure class rating, manufacturer's name, and the seal or mark of the laboratory making the evaluation of the suitability of the pipe for the transport of potable water.

4. Fittings for HDPE pipe shall conform to AWWA C906 and shall have the same pressure rating as the pipe in which they are installed.
5. Provide tracer wire and location/testing markers.

F. GRINDER PUMP PRESSURE SEWER PIPE AND FITTINGS

1. Grinder pump pressure sewer pipe and laterals shall be constructed of HDPE conforming to AWWA C901, DR 9, for sizes 1/2-inch to 3-inches in diameter with butt weld joints.
2. All fittings and joints shall have a working pressure rating at least equal to the pipe to which they are attached.

G. TRACER WIRE:

1. Install 10-gauge solid tracer wire with buried pipe and force main where specified. Wire shall be continuous and terminate at valve boxes, manholes, cleanouts, or testing markers. Wire shall be taped to the pipe a minimum of 3 times per length of pipe for all pressure piping except piping carrying combustible material. For pipe carrying combustible material, the tracer wire shall be placed in the trench directly above the pipe, maintaining 6 inches separation between the tracer wire and the pipe. Any splices in copper wire shall be soldered and fitted with a Raco, or equal, insulated watertight boot.
2. Tracer wire testing markers shall be installed a minimum of every 1,000 feet along the force main. The tracer wire shall run into and up the sides of all manholes and be secured near the casting.

H. MARKING TAPE:

1. Marking tape shall have a solid metal core with a plastic covering that will not degrade in alkalis or acids. The tape shall be three inches wide, green in color, have a printed legend indicating a buried pipeline and shall be capable of elongating 60%. Tape shall be Terra Tape Sentry Line 1350 or equal.
2. Clips for splices and connections shall be supplied by the tape manufacturer.

2.06 VALVES

- A. Valves shall conform to Section 9.

2.07 TAPPING SADDLES

- A. Tapping saddles shall be provided for all air release valve and grinder pump force main connections. Tapping saddles shall be Mueller, Ford, or equal, brass, 150 psi working pressure with stainless steel bands, nuts, and bolts.

2.08 SEWER SERVICE BRANCH AND LATERALS

- A. Wye or tee branches: Wherever required, wye or tee branches shall be provided for use in making sanitary sewer service and storm sewer inlet connections. Wye or tee branches for sanitary sewer service lateral connections to single-family residences shall be 6-inch-diameter minimum. All other sanitary sewer service laterals shall be 8-inch minimum.
- B. Sanitary sewer service branches shall be turned so that the branch is at an angle of 30° or 45° with the horizontal.
- C. Installation and Testing Requirements: Except for those branches that are to be used on storm sewers or for extending sanitary sewer service laterals, wye and tee branches shall be closed with airtight stoppers blocked to withstand air test pressure.
- D. The ends of all laterals shall be plugged and blocked to resist air test pressures. All plugs shall be manufactured to fit the pipe used and shall be watertight. The ends of all laterals shall be marked using flagging tape and 2 by 4 markers.
- E. All new laterals shall have tracer wire that extends from the sewer main to the building cleanout, see Figure 8-8.
- F. A complete and accurate tabulation of length, depth, and location of all branches, risers, and laterals shall be kept by Contractor. Measurements shall be made from the nearest downstream manhole. Lateral installation to meet these Specifications and field conditions are the responsibility of Contractor.

PART 3-EXECUTION

3.01 INSTALLATION

- A. Underground Piping:
 - 1. For restrained pipe joints, all underground forcemain pipe joints (except for the branch of tees and dead ends) shall be restrained to the length listed below in all directions from all bends and fittings. The branch of tees and all dead ends shall be restrained to two times the length listed below. Where wall penetrations occur at less than the length indicated below, the wall fittings shall also be restrained. Additional restraint shall be provided inside of structures as required.

Pipe Size, Inches	Test Pressure, psi				
	10	25	50	100	150
3-12	5	18	18	36	36
14-18	5	18	18	36	54
20-24	5	18	36	54	72
30	10	18	36	72	90
36	10	18	36	72	

42	10	36	54	90
48	10	36	54	90
Minimum Length (in Feet) Restrained Pipe from Bends or Fittings (Minimum 4 Feet Bury Depth)				

2. Except where noted or specified, ductile iron piping shall be installed in accordance with AWWA C600.
3. PVC sewer shall be installed in accordance with ASTM D2321. Except where noted or specified, PVC or other thermoplastic pressure piping shall be installed in accordance with ASTM D2774.
4. Reinforced concrete pipe shall be installed in accordance with ASTM C12.
5. Contractor shall excavate and lay all pipe to line and grade with bell ends uphill wherever possible. If not possible, Contractor shall excavate and lay pipe to line and grade with bell ends in the direction of laying. Grade stakes will be required for all lines.
6. Where piping is laid in native soil, the width of trench below the top of the pipe shall not exceed the nominal diameter of the pipe plus 2 feet for all pipelines. Where the maximum trench width is exceeded, the pipe shall be placed in a concrete cradle or a stronger pipe used.
7. Except as otherwise specified, all underground pipe within the right-of-way shall be bedded in crushed stone aggregate. Contractor shall perform all necessary excavation and shall provide all required materials to provide this bedding. Except as otherwise specified, bedding material shall conform to the requirements of INDOT No. 8 aggregate.
8. No materials native to the trench shall be used as bedding material unless they meet the above specification.
9. Immediately before placing the pipe, bedding shall be shaped by hand to fit the entire bottom quadrant of the pipe between bell holes. Bell holes shall be large enough to permit proper making of the joint but not larger than necessary to make the joint. All adjustments to line and grade must be done by scraping away or filling in bedding under the body of the pipe. Bedding must be tamped into place. If necessary to obtain uniform contact of the pipe with the bedding, a template shall be used.
10. Any pipe or fittings cracked in cutting or handling or otherwise not free from defects shall not be used. Pipe must be kept clean of mortar, cement, clay, sand, or other material. When PVC piping is installed during hot weather, it shall be laid in the trench with slack or permitted to cool to ground temperature before it is cut to length for making final connections. PVC expansion joints shall be provided where needed.
11. Trenches shall be kept water-free and dry during bedding, laying, and jointing. Contractor shall provide, operate, and maintain all pumps or other equipment necessary to drain and keep all excavation pits and

trenches and the entire subgrade area free from water under any and all circumstances that may arise.

12. Material that is to be placed from the bedding material around and to 1 foot above the top of all pipes shall be termed cover material. Except as otherwise specified, cover material shall conform to the requirements of INDOT No. 8 aggregate.
13. Cover material shall be deposited in the trench for its full width on each side of the pipe, fittings, and appurtenances simultaneously. Cover material (minimum 12 inches) shall be placed over the top of the pipe in 3-inch layers and shall be compacted using hand tamping bars and/or mechanical tampers.
14. Compaction shall be equivalent to that described under "Compacted Fill and Backfill" as specified in Section 2.
15. General Excavation:
 - a. All trees, shrubs, and improved areas outside the excavation shall be protected from damage.
 - b. Work shall conform to other sections of Section 2, except where modified by this section.
 - c. Pipe shall be placed only on dry foundations.
 - d. The bottom of the excavation shall be leveled off, all loose and disturbed soil shall be removed, and it shall be hand-tamped prior to pipe, manhole, etc., installation.
 - e. The excavation at the crossing of all underground utility services in place shall be as narrow as practicable. All underground services shall be protected from damage and maintained in service at their original location and grade during the process of the work. Any damage to underground services shall be replaced or repaired at no cost to the City or to the owner of the service.
 - f. Excavated native material that is unsuitable or not required for filling shall be removed from the site. Materials to be used for fill and suitable for this purpose shall be deposited where required except that no fill shall be placed where trenches for sewers or other services will be located until after the trench work is completed.
 - g. Any water, drainage, gas, sewer, or electric lines encountered in the excavation that are not to be disturbed shall be properly underpinned and supported. Any service connections encountered that are to be removed shall be cut off at limits of the excavation and capped in accordance with the requirements of or permits governing such removals.

B. Manholes and Inlets:

1. The maximum distance between manholes is four hundred (400) feet, unless otherwise approved by the City.
2. When required by the City, the owner of any property served by a building sewer carrying industrial wastes shall install a suitable control manhole in the building sewer to facilitate observation sampling and measurement of wastes.
3. Manholes in unpaved areas shall be built to a rim elevation higher than the original ground. The ground surface shall be graded to drain away from the manhole. Fill shall be placed around manholes to the level of the upper rim of the manhole frame, and the surface evenly graded on a one (vertical)-to-five (horizontal) slope to surrounding ground, unless otherwise directed by the City.
4. Manholes in paved areas shall be constructed to meet final surface grade. Manholes shall not project above finished roadway pavements.
5. Contractor shall be solely responsible for proper height of manholes necessary to reach final grade.

3.02 FIELD QUALITY CONTROL AND TESTING

- A. All work shall be inspected, tested, and approved in accordance with federal, state, and local rules and regulations. All work shall also be tested as specified in this section. Test results shall be recorded and reports or appropriate certificates shall be submitted to the City in triplicate.
- B. All new piping shall be tested. All underground piping shall be backfilled or properly secured to avoid damage during testing. Should underground piping fail test, Contractor shall be responsible for removal and replacement of backfill. All piping, interior or exposed, shall be subject to test before being covered with insulation or paint. All piping and appurtenances shall be watertight or airtight and free from visible leaks. Manholes and precast reinforced concrete wet wells and appurtenances shall be free of any visible leaks. Any leakage shall be sealed from the exterior of the manhole or structure. Precast reinforced concrete manhole risers and tops shall be tested in accordance with ASTM C497.
- C. All piping shall be flushed or blown out after installation prior to testing. Contractor shall provide all necessary piping connections, water, air, test pumping equipment, water meter, bulkheads, valves, pressure gauge and other equipment, materials, and facilities necessary to complete the specified tests. Contractor shall provide all temporary sectionalizing devices and vents for testing.
- D. Force main:
 1. Contractor shall conduct hydrostatic pressure tests and leakage tests of all joints in accordance with the requirements of AWWA C600 for iron

pipe and AWWA C605 for PVC pipe. During performance of the hydrostatic pressure test, force main shall be tested to 200% of normal operating pressure in the main, but to no more than the pressure rating of the pipe. All air shall be removed from the main during testing. This shall be done by flushing, by installing corporations at high points, or by releasing air at valves at high points. Test pumping equipment used shall be centrifugal pumps or other pumping equipment that will not place shock pressures on the main. Power plunger pumps will not be permitted for use on closed pipe systems. Pumps shall be disconnected during test periods.

2. Prior to conducting the pressure and leakage test, Contractor shall backfill the trench for its full depth. All bends and special connections to the main shall be adequately blocked and tied prior to the test. Any damage caused to the main or its appurtenances during performance of these tests shall be corrected by Contractor at its expense.
3. Contractor shall keep a record of all tests performed. These records shall show the individual lengths of main tested and test results.
4. Where connections are made to existing mains, it shall be the responsibility of Contractor to provide the necessary hydrostatic tests on all new mains installed. This may necessitate, but is not limited to, the installation of temporary valves to isolate the new system from the existing system. All materials, Work, and equipment necessary for this Work shall be furnished by Contractor at its expense.
5. All testing of pipelines shall proceed concurrently with installation. Contractor is advised that it may be advantageous to conduct daily preliminary testing of its Work.

E. INFILTRATION/EXFILTRATION TESTS

1. Infiltration/exfiltration tests for all gravity sewers, except laterals, will be as follows: If groundwater is above the pipe, measurements shall be taken to determine the rate of infiltration into the pipe. If groundwater is below the pipe, the stretch of pipe shall be plugged at its downstream end and water shall be placed inside the pipe to fill the pipe. Measurements shall then be taken to determine the rate of leakage out of the pipe by filling the pipe. Concrete pipe shall be filled with water at least 8 hours before measurements are taken. The rate of infiltration or leakage shall not exceed 200 gallons per inch-diameter per mile per day for any stretch of pipe measured. Contractor shall immediately make all necessary repairs to bring infiltration or leakage within the above acceptable limits.
2. Air test procedure may be used for the above-listed pipe designations and shall be conducted as follows:
 - a. Clean pipe to be tested.

- b. Plug all pipe outlets with suitable test plugs. Brace each plug securely. Add air slowly to the portion of the pipe installation under test until the internal air pressure is raised to 4.0 psig.
- c. After an internal pressure of 4.0 psig is obtained, allow at least two minutes for air temperature to stabilize, adding only the amount of air required to maintain pressure.
- d. When pressure decreases to 3.5 psig, start stopwatch. Determine the time in seconds that is required for the internal air pressure to reach 2.5 psig. Minimum permissible pressure holding times for runs of single pipe diameter and for systems of 4-inch, 6-inch, or 8-inch laterals in combination with trunk lines shall be as recommended by National Clay Pipe Institute.
- e. If the pipe to be tested is submerged in groundwater, determine the height of groundwater above the crown of the sewer. This is the pressure head of water above the pipe because of groundwater submergence over the sewer. All gauge pressures in the test should be increased by the pressure head of water above the pipe.
- f. The air test may be dangerous if a line is improperly prepared. It is extremely important that the various plugs be installed and braced in such a way as to prevent blowouts. Inasmuch as a force of 250 pounds is exerted on an 8-inch plug by an internal pipe pressure of 5 psi, it should be realized that sudden expulsion of a poorly installed plug or of a plug that is partially deflated before the pipe pressure is released can be dangerous.
- g. As a safety precaution, pressurizing equipment should include a regulator set at 10 psi to avoid overpressurizing and damaging an otherwise acceptable line. No one shall be allowed in the manholes during testing.

F. DEFLECTION TESTING

- 1. All PVC pipe used for sanitary sewer, except laterals, shall be tested for vertical deflection. Maximum deflection after completion of backfilling shall be 5% of the inside pipe diameter. Testing shall not be started until trench backfill has been in place for 30 days. Contractor shall keep a record of all tests performed. These records shall show the individual lengths of main tested and test results. Deflection shall be measured by pulling a mandrel with a vertical diameter equal to 95% of the pipe inside diameter through the line, after thoroughly flushing the lines to be tested. The testing device shall be controlled using cables at both the upstream and downstream manholes. The testing device must pass freely through the sewer without the use of unreasonable force on the control cables. Any line that will not pass the test cylinder will not be accepted until the faulty sections have been removed and replaced and the line retested.

2. Deflection testing of thermoplastic storm sewer shall be provided in accordance with the above requirements.

G. MANHOLE TESTING

1. Sanitary sewer manholes shall be vacuum tested in accordance with ASTM C1244. Pipes entering the manhole shall be plugged and the seal inflated in accordance with manufacturer's recommendations.
2. Vacuum testing of storm sewer and other manholes will not be required.

H. TELEVISED INSPECTION

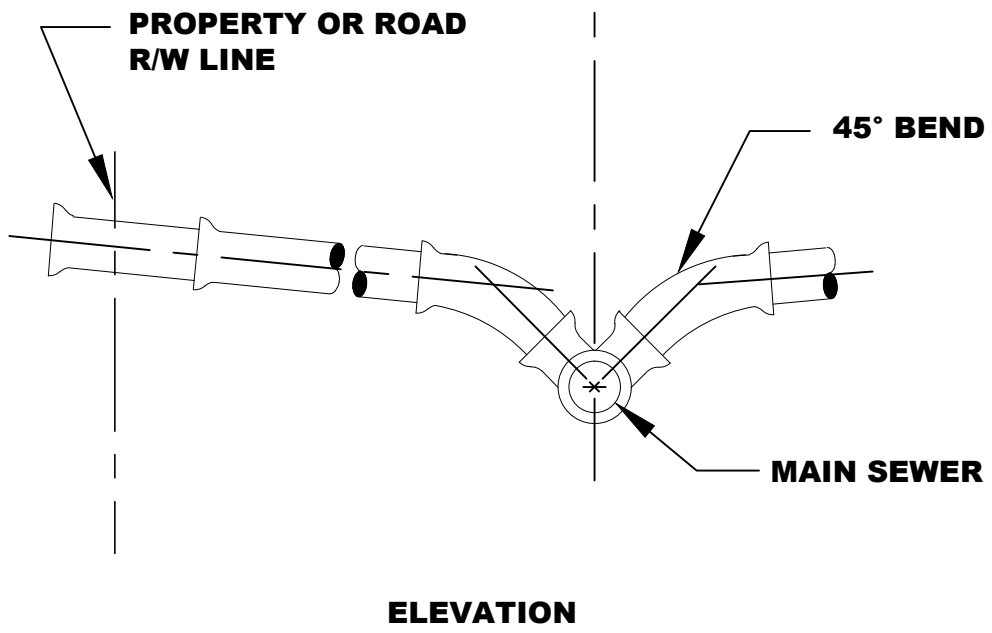
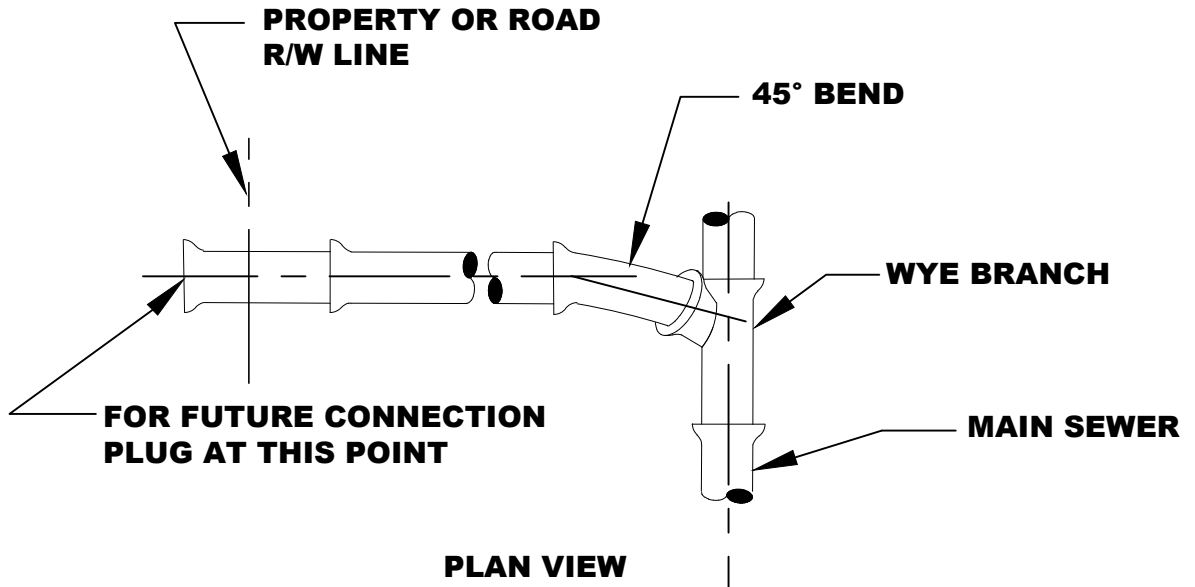
1. Where requested by the City, a color televised survey of installed sanitary sewer shall be provided after air testing to confirm branch locations, verify cleanliness of sewer, and confirm presence or absence of sags or deviations in sewer alignment. Sewers shall be cleaned immediately prior to the survey. The survey shall conform to NASCO PACP standards.
2. Televised inspection of storm sewers will not be required.

3.03 REPAIR AND RESTORATION

- A. Pavement Repair: Unless otherwise specified, Contractor shall replace all bituminous and concrete pavement removed or damaged during performance of the work. Concrete pavement replacement shall conform to Section 7.
- B. Cleanup:
1. Upon completion of the work, all improvements disturbed by Contractor's operations shall be repaired or replaced. Broken concrete, rubble fill, and other excess material shall be removed from the site and wasted.
 2. All areas used for the storage of materials or the temporary deposit of excavated earth shall be leveled off and cleaned up. All surplus material, tools, and equipment shall be removed, and the premises shall be left free of everything of the kind.
 3. All pipes and manholes shall be flushed until clean, and all debris and mud shall be removed.

END OF SECTION

File: S:\COL\4100--4199\4122\067\Acad\Sanitary\Standard Service Connection.dwg Time: Feb 04, 2014 - 9:45am



STANDARD SERVICE CONNECTION

NO SCALE

SECTION 8
BURIED PIPING, MANHOLES, AND APPURTENANCES
STANDARD CONSTRUCTION SPECIFICATIONS
STANDARD SERVICE CONNECTION
CITY OF SEYMOUR
SEYMOUR, INDIANA



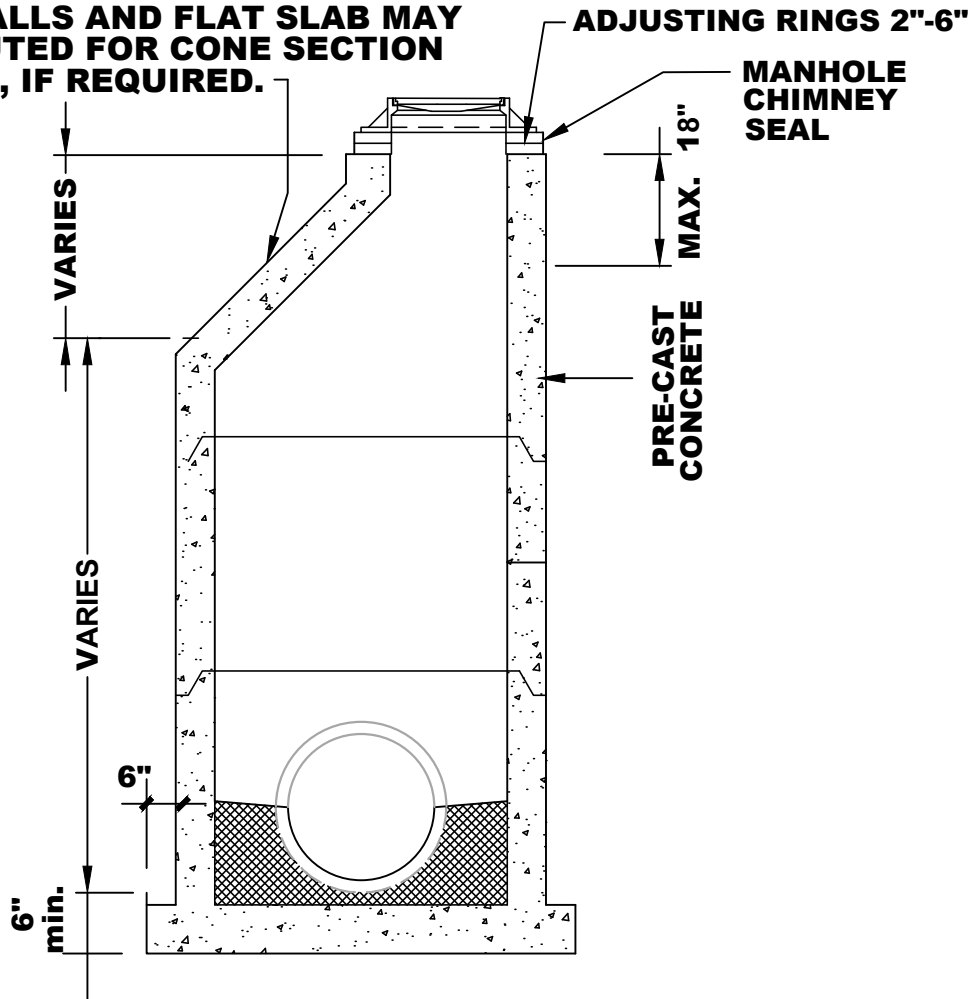
FIGURE 8-1

4122.067

NOTES:

1. Use East Jordan Iron Works type 1050Z1 or 1037Z manhole frame and cover.
2. Where manholes occur in flood plain use watertight casting and lids, as approved by the City.
3. All joints to be watertight "O" ring type per A.S.T.M. Specification C-443, latest edition.
4. All precast cones and barrels to be reinforced per A.S.T.M. Specification C-478, latest edition.
5. $\frac{1}{2}$ " Mastic to be applied between joints of precast risers and joint between casting and risers.
6. All manhole joints shall be grouted on interior with non-shrinking mortar including the adjustment rings. All exterior joints to have butyl rubber applied over the joints a minimum of 6" above and below the joint.

VERTICAL WALLS AND FLAT SLAB MAY BE SUBSTITUTED FOR CONE SECTION OF MANHOLE, IF REQUIRED.



**STANDARD DETAIL FOR TYPICAL
PRECAST MANHOLE WITH CONE**

NO SCALE

File: S:\COL\4100--4199\4122\067\Acad\Sanitary\Typical Precast Manholes.dwg Time: Feb 04, 2014 -- 9:45am

**SECTION 8
BURIED PIPING, MANHOLES, AND APPURTENANCES
STANDARD CONSTRUCTION SPECIFICATIONS
STANDARD PRECAST MANHOLE
CITY OF SEYMOUR
SEYMOUR, INDIANA**

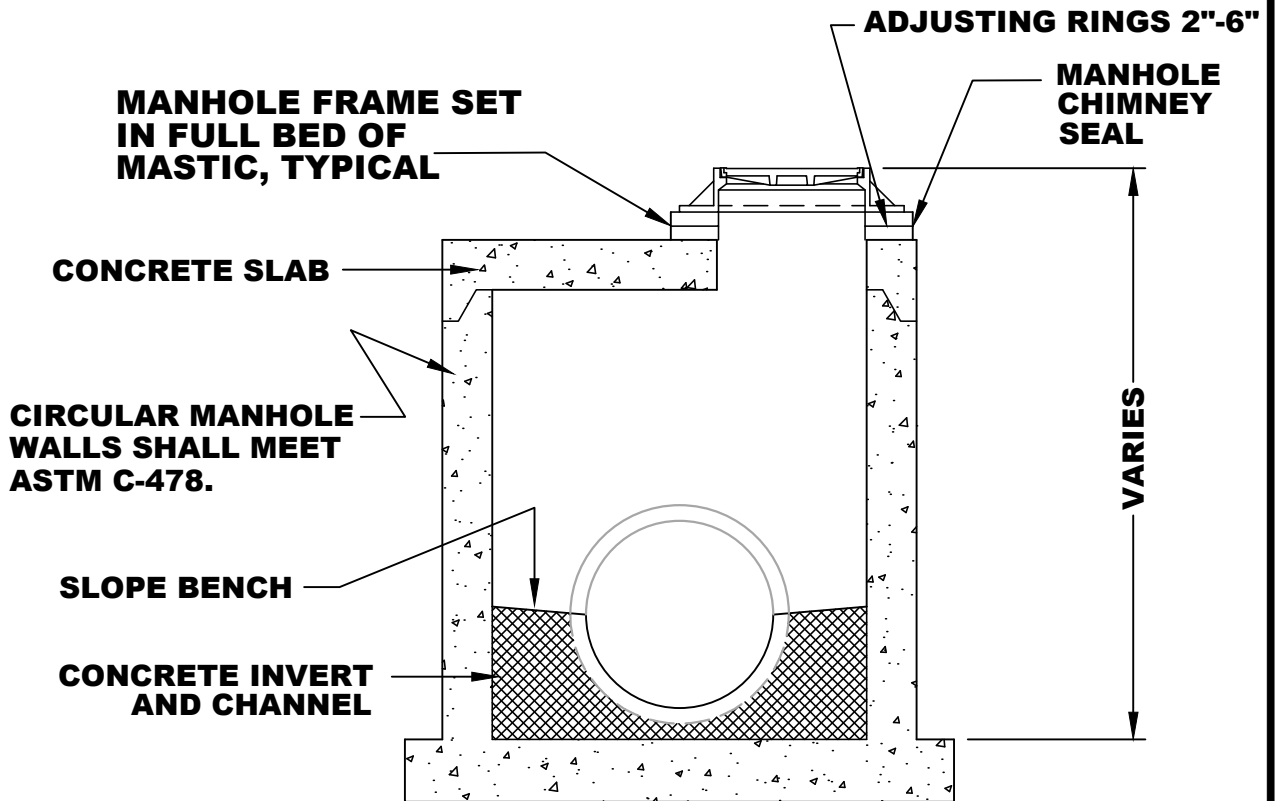


FIGURE 8-2

4122.067

NOTES:

1. Use East Jordan Iron Works type 1050Z1 or 1037Z manhole frame and cover.
2. Where manholes occur in flood plain use watertight casting and lids, as approved by the City.
3. All joints to be watertight "O" ring type per A.S.T.M. Specification C-443, latest edition.
4. All precast cones and barrels to be reinforced per A.S.T.M. Specification C-478, latest edition.
5. $\frac{1}{2}$ " Mastic to be applied between joints of precast risers and joint between casting and risers.
6. All manhole joints shall be grouted on interior with non-shrinking mortar including the adjustment rings. All exterior joints to have butyl rubber applied over the joints a minimum of 6" above and below the joint.



FLAT TOP MANHOLE

NO SCALE

File: S:\COL\4100--4199\4122\067\Acad\Sanitary\Typical\Precast Manholes.dwg Time: Feb 04, 2014 -- 9:45am

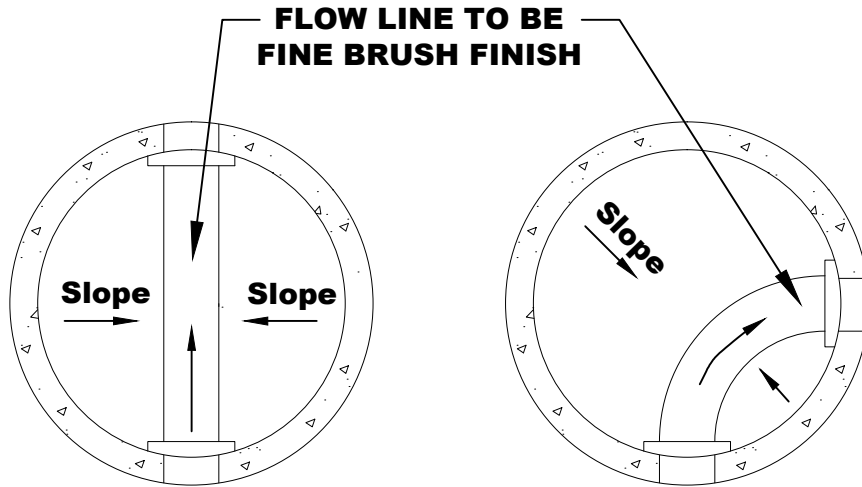
SECTION 8
BURIED PIPING, MANHOLES, AND APPURTENANCES
STANDARD CONSTRUCTION SPECIFICATIONS
FLAT TOP MANHOLE
CITY OF SEYMOUR
SEYMOUR, INDIANA



FIGURE 8-3

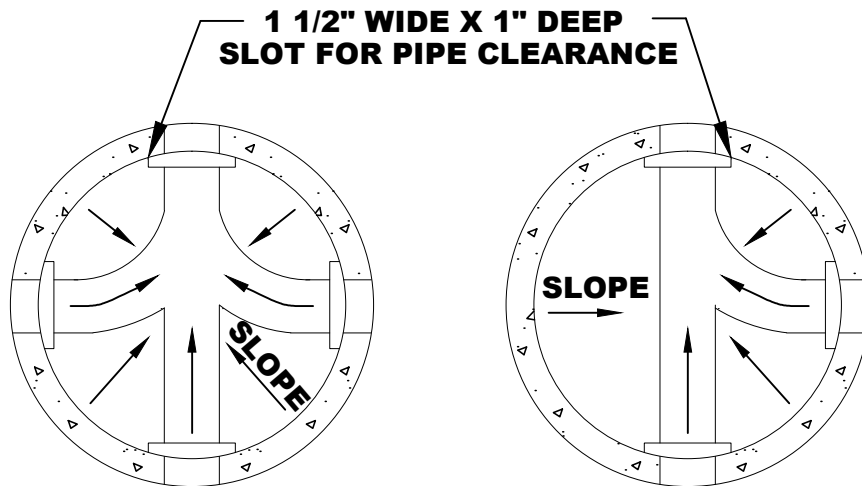
4122.067

File: S:\COL\4100--4199\4122\067\Acad\Sanitary\Flowlines.dwg Time: Feb 04, 2014 -- 9:45am



TYPICAL STRAIGHT FLOW

TYPICAL CURVE FLOW



TYPICAL 4-WAY FLOW

TYPICAL 3-WAY FLOW

MANHOLE FLOWLINES

NO SCALE

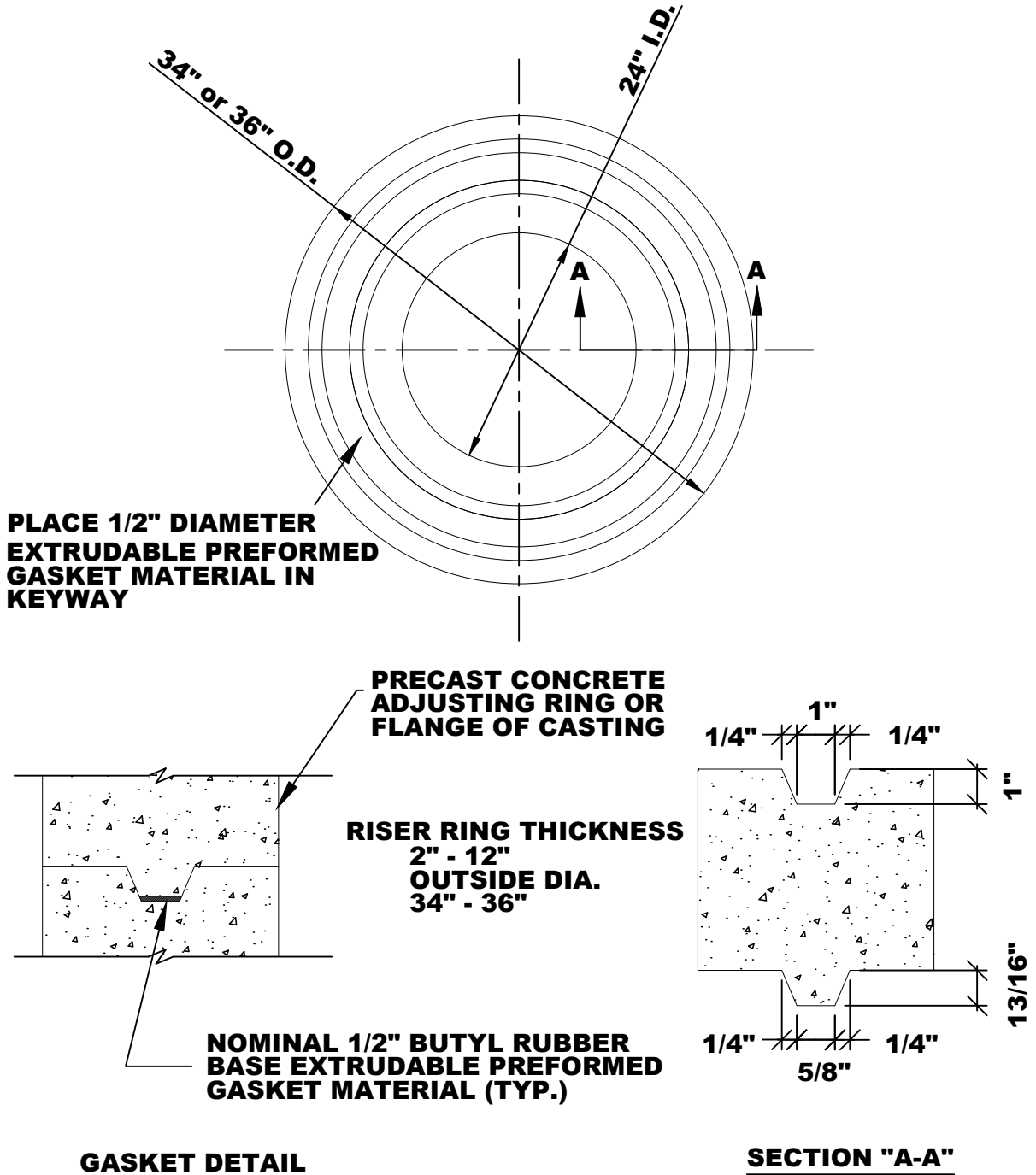
**SECTION 8
BURIED PIPING, MANHOLES, AND APPURTENANCES
STANDARD CONSTRUCTION SPECIFICATIONS
MANHOLE FLOWLINES
CITY OF SEYMOUR
SEYMOUR, INDIANA**



FIGURE 8-4

4122.067

File: S:\COL\4100--4199\4122\067\Acad\Sanitary\Adjusting Ring Detail.dwg Time: Feb 04, 2014 - 9:45am



ADJUSTING RING DETAIL

NO SCALE

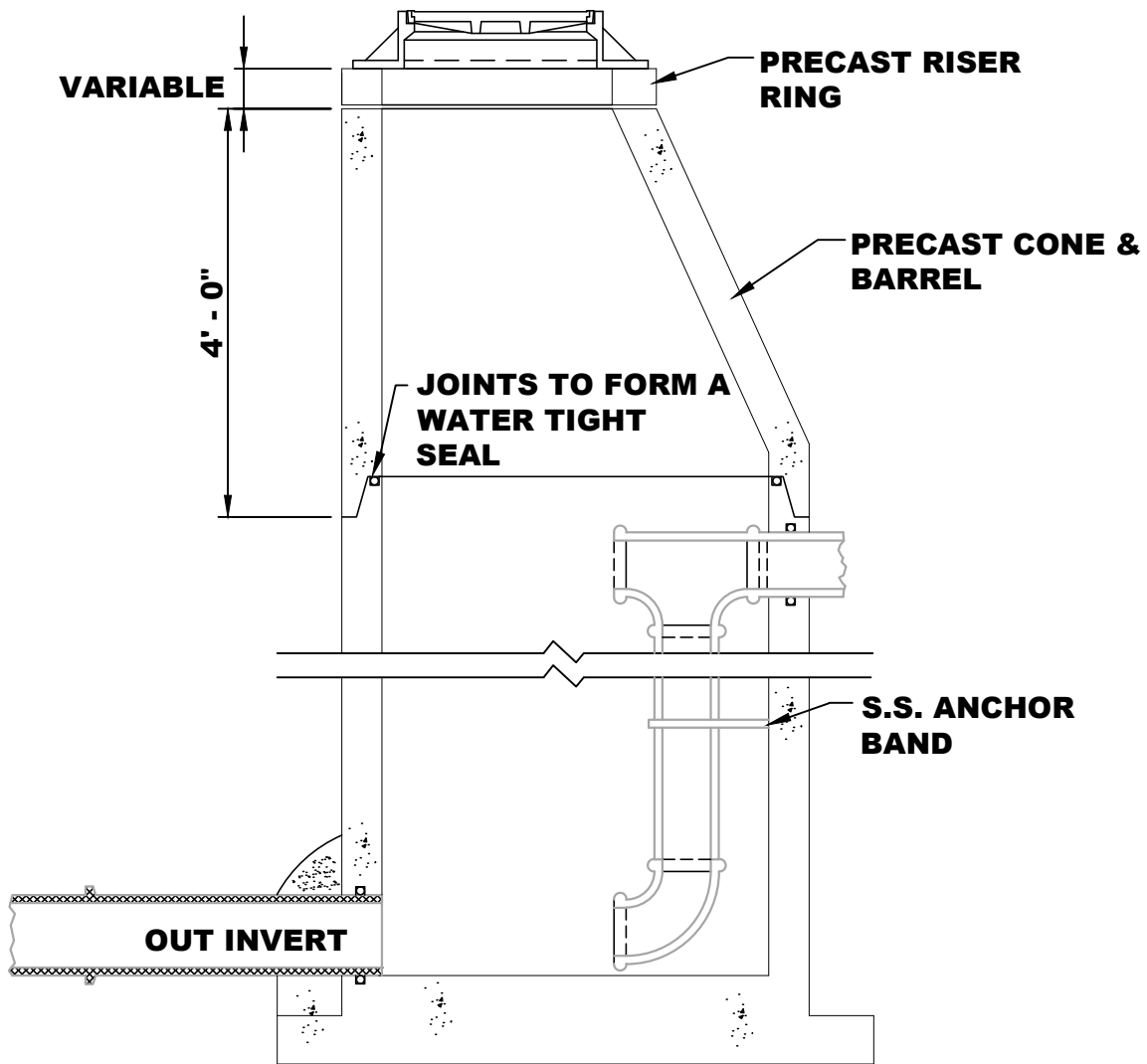
**SECTION 8
BURIED PIPING, MANHOLES, AND APPURTENANCES
STANDARD CONSTRUCTION SPECIFICATIONS
ADJUSTING RING DETAIL
CITY OF SEYMOUR
SEYMOUR, INDIANA**



FIGURE 8-5

4122.067

File: S:\COL\4100--4199\4122\067\Acad\Sanitary\Drop Manhole.dwg Time: Feb 04, 2014 - 9:45am



NOTE:
DROP SHALL BE INSTALLED TO DISCHARGE DIRECTLY INTO FLOW LINE AND NOT ONTO MANHOLE BENCH

INSIDE DROP MANHOLE

NO SCALE

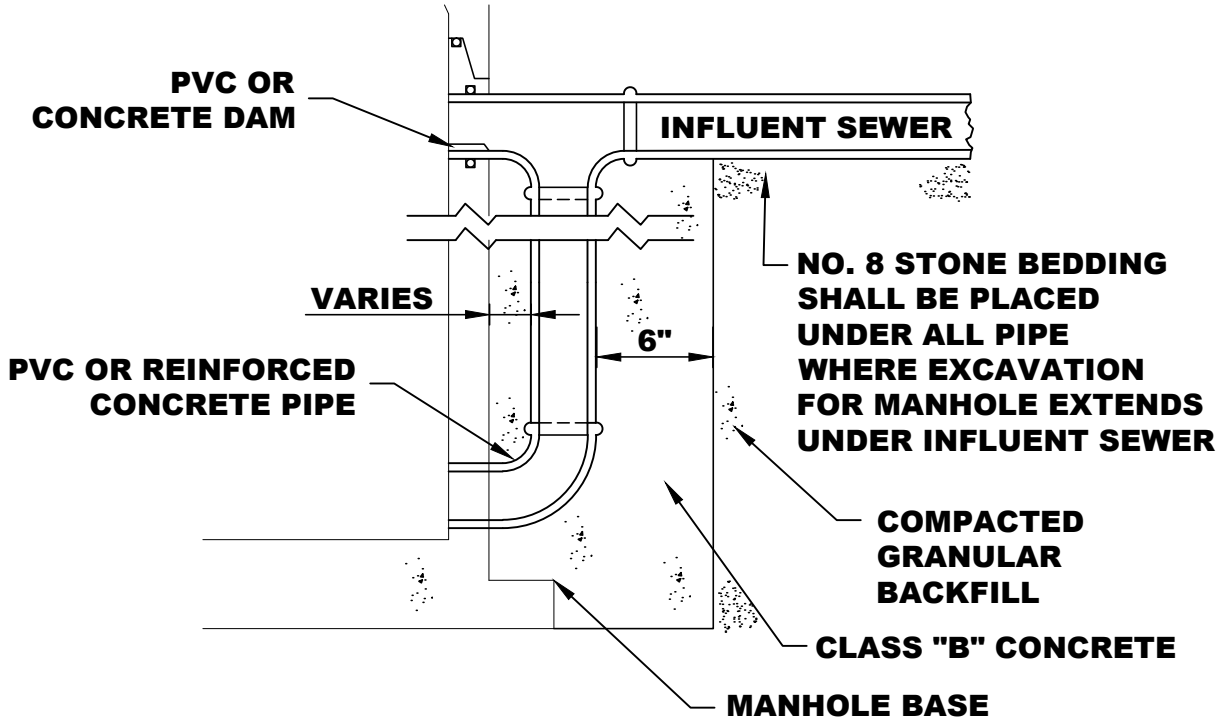
SECTION 8
BURIED PIPING, MANHOLES, AND APPURTENANCES
STANDARD CONSTRUCTION SPECIFICATIONS
DROP MANHOLE
CITY OF SEYMOUR
SEYMOUR, INDIANA



FIGURE 8-6

4122.067

File: S:\COL\4100--4199\4122\067\Acad\Sanitary\Drop Manhole Pipe Details.dwg Time: Feb 04, 2014 - 9:45am



OUTSIDE DROP MANHOLE

NO SCALE

SECTION 8
BURIED PIPING, MANHOLES, AND APPURTENANCES
STANDARD CONSTRUCTION SPECIFICATIONS
DROP MANHOLE
CITY OF SEYMOUR
SEYMOUR, INDIANA

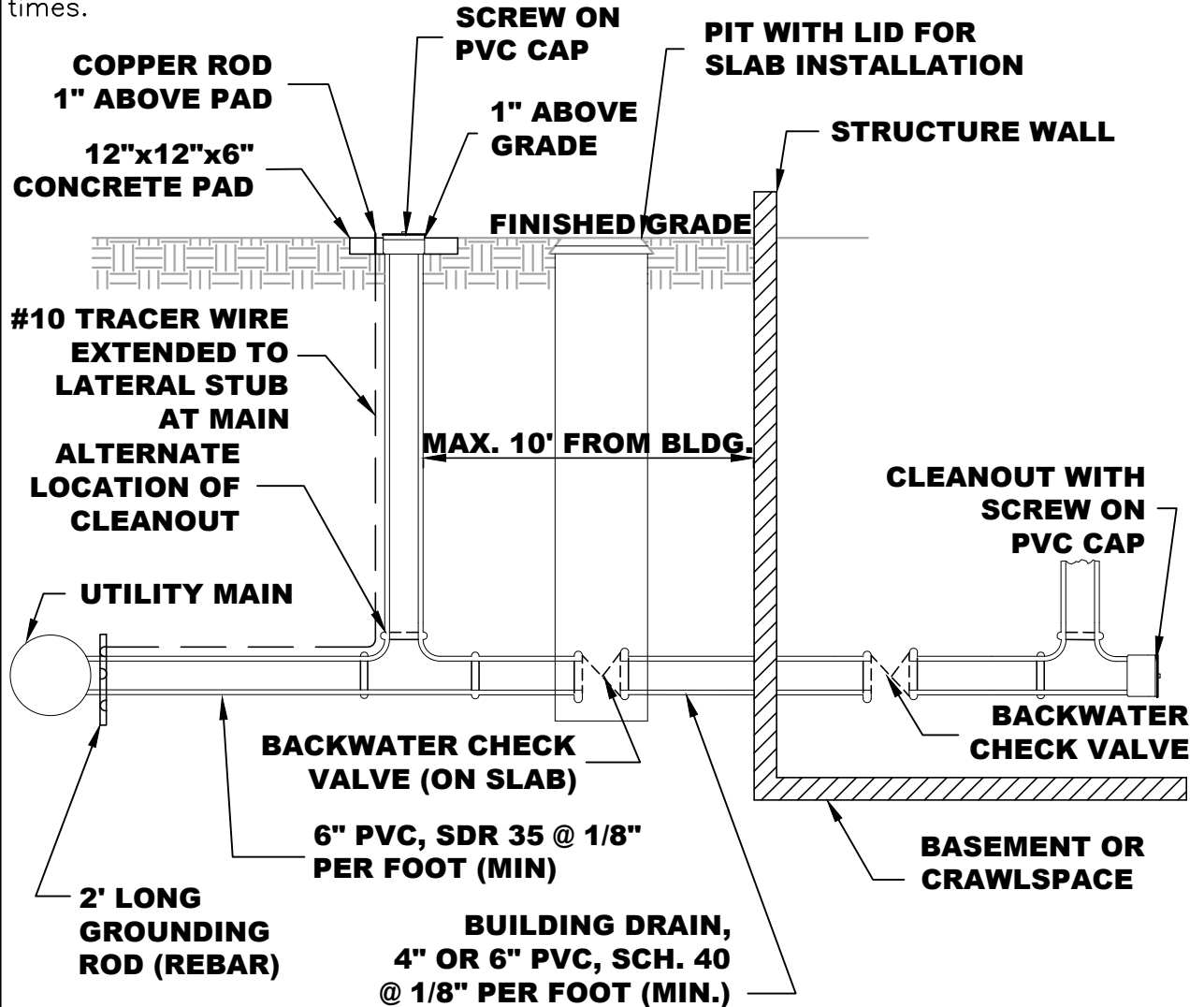


FIGURE 8-7

4122.067

Note:

Tracer wire to be wrapped around ground rod min. 3 times.



Cleanout Locations:

1. At the junction of building drain and building sewer (near exterior face of building).
2. If building sewer is more than 100 feet from main line sewer, additional cleanout will be required. Cleanout spacing shall not exceed 100 feet.
3. A cleanout is required at each bend that is greater than or equal to 45 degrees.
4. There shall be no basement drains or sump pumps connected to service connection

SERVICE CLEANOUT

NO SCALE

SECTION 8 BURIED PIPING, MANHOLES, AND APPURTENANCES

STANDARD CONSTRUCTION SPECIFICATIONS

SERVICE CLEANOUT

CITY OF SEYMOUR

SEYMOUR, INDIANA

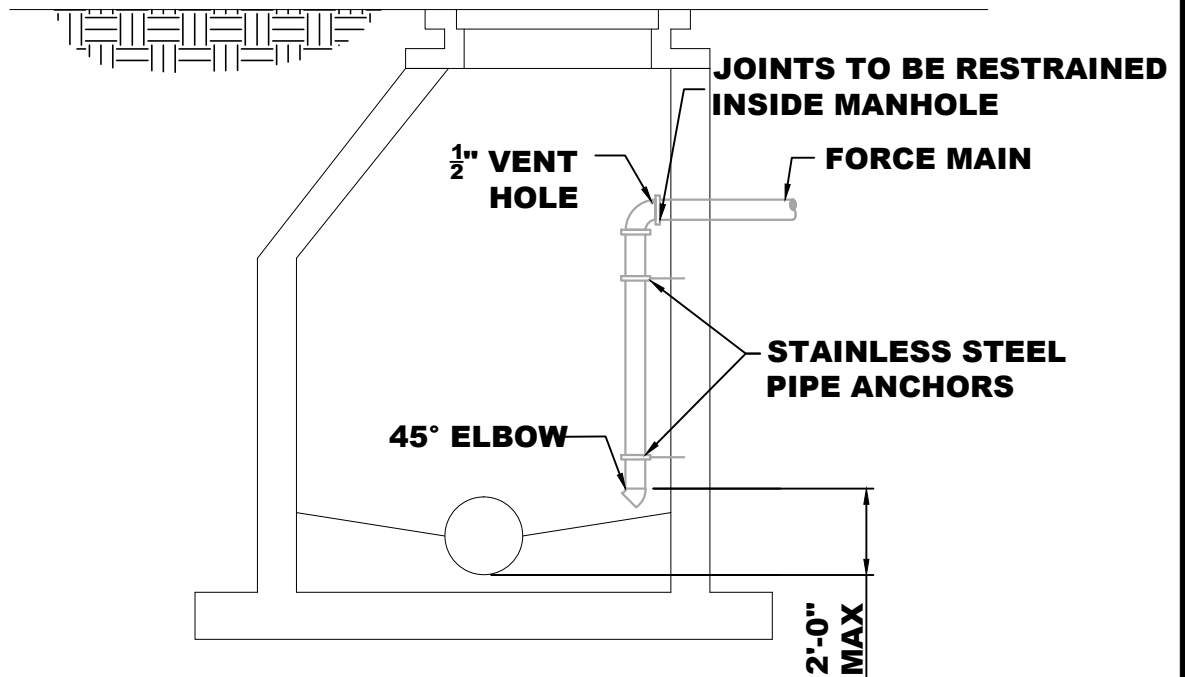


FIGURE 8-8

4122.067

File: S:\COL\4100--4199\4122\067\Acad\Sanitary\Residential Grinder Pump Station.dwg Time: Feb 04, 2014 - 9:45am

NOTE:
FORCE MAIN SHALL BE INSTALLED TO DISCHARGE DIRECTLY INTO FLOW LINE AND NOT ONTO MANHOLE BENCH.



FORCE MAIN TO MANHOLE CONNECTION

NO SCALE

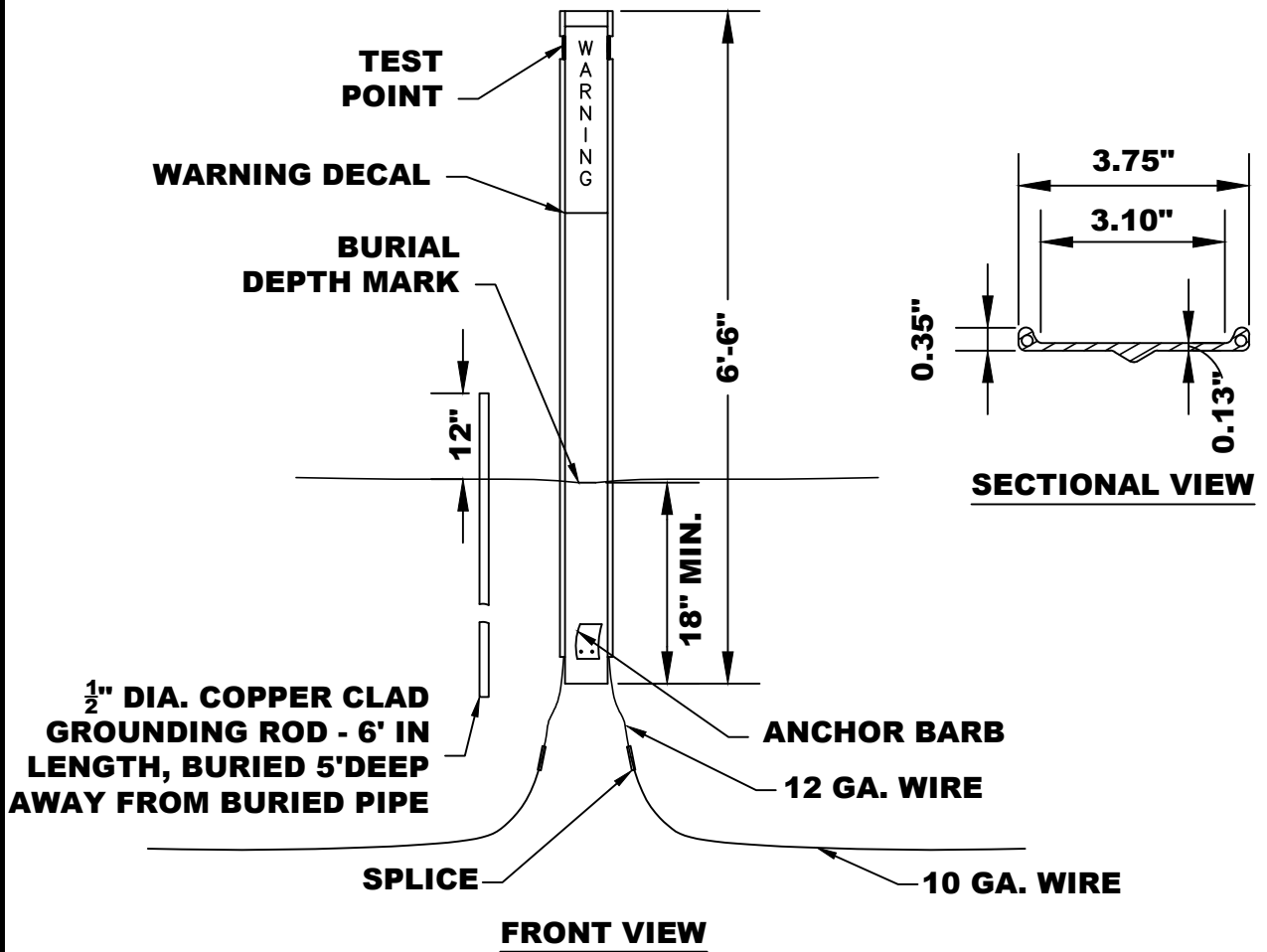
SECTION 8
BURIED PIPING, MANHOLES, AND APPURENANCES
STANDARD CONSTRUCTION SPECIFICATIONS
FORCE MAIN TO MANHOLE CONNECTION
CITY OF SEYMOUR
SEYMOUR, INDIANA



FIGURE 8-9

4122.067

File: S:\COL\4100--4199\4122\067\Acad\Testing Marker.dwg Time: Feb 04, 2014 - 9:45am



NOTES:
 THE LOCATOR WIRE SHALL BE INSTALLED ALONG THE TOP OF THE PIPE. THE WIRE SHALL BE TAPED TO THE PIPE A MINIMUM OF 3 TIMES PER LENGTH OF PIPE.

ONE (1) TESTING APPARATUS SHALL BE LOCATED EVERY 1000 FEET OF FORCE MAIN AND CONNECTED TO THE LOCATOR WIRE. ANY SPLICES IN THE LOCATOR WIRE SHALL BE SOLDERED AND FITTED WITH HEAT STRINK, INSULATED WATERTIGHT BOOT.

TESTING MARKER

NO SCALE

SECTION 8
BURIED PIPING AND APPURTENANCES
STANDARD CONSTRUCTION SPECIFICATIONS
TESTING MARKER DETAIL
CITY OF SEYMOUR
SEYMOUR, INDIANA

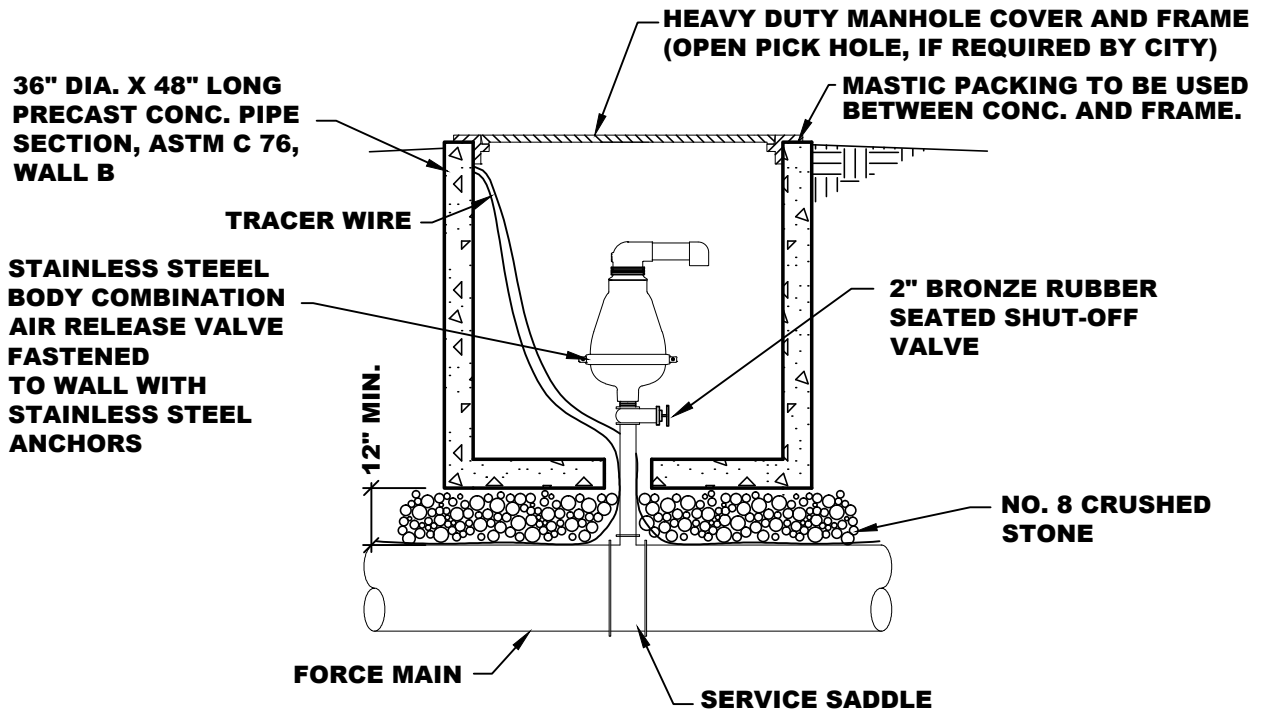


FIGURE 8-10

4122.067

NOTES:

COMBINATION AIR RELEASE VALVES TO BE FIELD LOCATED AT HIGH POINTS.



**COMBINATION AIR
RELEASE VALVE**

NO SCALE

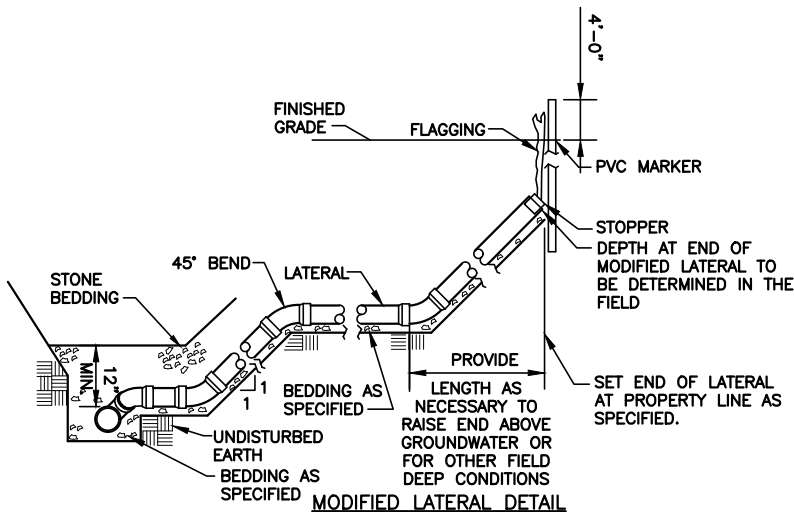
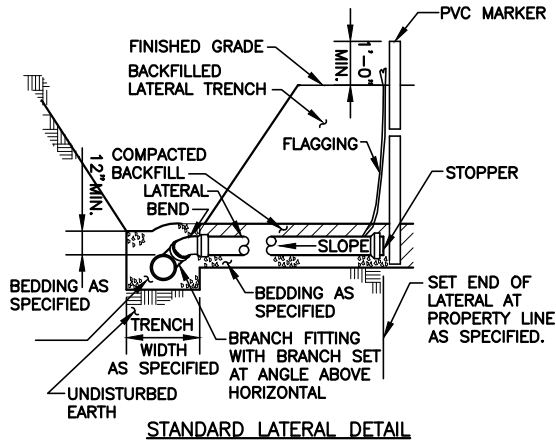
File: S:\COL\4100--4199\4122\067\Acad\Sanitary\Air Release Valve.dwg Time: Feb 04, 2014 - 9:45am

**SECTION 8
BURIED PIPING AND APPURTENANCES
STANDARD CONSTRUCTION SPECIFICATIONS
AIR RELEASE VALVE DETAIL
CITY OF SEYMOUR
SEYMOUR, INDIANA**



FIGURE 8-11

4122.067



NOTES:

1. ALL WORK SHALL BE DONE IN ACCORDANCE WITH THE REQUIREMENTS OF REGULATORY BODIES OF THE STATE AND APPLICABLE MUNICIPAL ORDINANCES.
2. DETAILS RELATIVE TO ITEMS SHOWN ON THIS DRAWING SHALL CONFORM TO THE PERTINENT REQUIREMENTS OF THE SPECIFICATIONS.
3. VARIATIONS IN DIMENSIONS AND DESIGN MAY BE PERMISSABLE, PROVIDING EQUIVALENT CAPACITY AND STRENGTH ARE ATTAINED.
4. ALL NEW CONSTRUCTION SHALL BE PLACED ON UNDISTURBED EARTH OR STONE BEDDING.
5. BEDDING CLASSES SHALL CONFORM TO THE PERTINENT REQUIREMENTS OF THE SPECIFICATIONS.
6. ALL 4" LATERALS SHALL BE LAID AT A STANDARD SLOPE OF 1/4-INCH PER FOOT. 6" LATERALS SHALL BE LAID AT A STANDARD SLOPE OF 1/8-INCH PER FOOT. MAXIMUM LATERAL SLOPE SHALL BE 1 TO 1.
7. END PLUGS OR STOPPERS FOR THE ENDS OF LATERALS AND BRANCH FITTINGS SHALL BE PROVIDED.
8. A PVC MARKER SHALL BE PLACED AT ALL LATERAL ENDS SO THAT IT PROTRUDES 48 INCHES ABOVE FINISHED GRADE. THE PVC MARKER SHALL BE CONTINUOUS FROM THE END OF THE LATERAL TO 48 INCHES ABOVE GRADE. THE LOWER END OF THE PVC MARKER SHALL BE PLACED AGAINST THE END OF THE LATERAL. PVC MARKERS SHALL BE MARKED "LATERAL" OR PAINTED GREEN.
9. BAR STEEL REINFORCEMENT SHALL BE IMBEDDED 1 1/2-INCH CLEAR MINIMUM.
10. STANDARD LATERALS AND MODIFIED LATERALS SHALL BE CONSTRUCTED OF MATERIAL AS SPECIFIED.
11. FLAGGING SHALL BE AS SPECIFIED. TIE FLAGGING AROUND END OF ALL LATERALS AND EXTEND UNBROKEN TO FINISHED GRADE DIRECTLY ABOVE ENDS OF LATERALS.
12. STONE BEDDING SHALL BE USED AROUND AND TO ONE FT. ABOVE TOP OF ALL SEWER MAINS AT LATERAL CONNECTIONS. PROVIDE BEDDING AS SPECIFIED.

**SECTION 8
BURIED PIPING AND APPURTENANCES
STANDARD CONSTRUCTION SPECIFICATIONS
SANITARY SEWER LATERALS
CITY OF SEYMOUR
SEYMOUR, INDIANA**



FIGURE 8-12

PIPELINE INSTALLATION REPORT

OWNER: _____ WEATHER: _____ DATE: _____
 CONTRACT: _____ REPORT BY: _____
 CONTRACTOR: _____ LINE AND GRADE BY: _____
 TYPE OF MAIN: SANITARY: _____ FORCE MAIN _____ STORM: _____ WATER: _____ OTHER: _____
 STREET: _____ FROM: _____ TO: _____ DRAWING NO.: _____
 STREET: _____ FROM: _____ TO: _____ DRAWING NO.: _____
 STREET: _____ FROM: _____ TO: _____ DRAWING NO.: _____

Pipe Laying	Station		Linear Feet	Size of Main	Type of Main	Kind of Pipe	Type of Joint	Class of Bedding	Trench Depth	Trench Width Top of Pipe	Rock Depth	Ground-Water Depth	Type of Backfill	Method of Trench Compaction
	From	To												
Excavating Interference Encountered		Size & Description			Station	Street			Depth	Damaged	Remarks			
Services Installed	Street	Type of Main		Type of Service	Size of Service	Length	Direction	Location	Remarks					

REMARKS: _____

ADDITIONAL REMARKS:

PIPE TESTING REPORT

PIPE SYSTEM: _____

LOCATION (SEE DRAWINGS): _____

TYPE OF PIPE MATERIAL: _____

TYPE OF TEST: _____

TEST PRESSURE: _____

TEST DURATION: _____

ALLOWABLE LEAKAGE: _____

ACTUAL LEAKAGE: _____

MANDREL TEST: _____

RESULTS: _____

DATE: _____ TIME: _____

CONTRACTOR: _____

CITY REPRESENTATIVE: _____

COMPUTATIONS:

HYDROSTATIC TESTING FOR FORCE MAIN/WATER MAIN

Project Name: _____ Job No.: _____
 Contractor: _____ Test Pressure: _____
 Duration of Test: _____ Limits of Test: _____

Allowable Water Loss

Pipe Size: _____ in. _____ in. _____ in. _____ in.
 Total Lengths: _____ in. _____ in. _____ in. _____ in.

Allowable Calculations

$$L = \frac{SD\sqrt{P}}{148,000}$$

L=Loss in gallons per hour
 P=Test pressure in pounds per square inch

D=Diameter of pipe in inches
 S=Length of pipe being tested in feet

Calculations

128 oz/gal

7.48 gal/ft³

Total Allowable Loss per Hour (Gallons)					
Test Number	Date	Allowable Loss	Actual Loss	Pass	Fail

Remarks: _____

Project Representative: _____
 Contractor: _____
 City Representative: _____

AIR TESTING REPORT

PROJECT _____

CLIENT _____

CONTRACT _____

CONTRACTOR _____

Date	Tested by:	Witness	MH to MH	<u>Length of Sewer</u> <u>Length of Lateral</u>	<u>Size of Sewer</u> <u>Size of Lateral</u>	Allowable Time (seconds)	Total lbs. Lost/Time	Pass	Fail	Remarks

SECTION 9

EXPOSED PIPING, VALVES AND APPURTENANCES

PART 1-GENERAL

1.01 SUMMARY

A. Work Included:.

1. All exposed piping, valves and appurtenances except as specified in Section 8.

PART 2-PRODUCTS

2.01 EXPOSED PIPE AND PIPE FITTINGS

A. Ductile Iron Piping and Ductile and Cast Iron Fittings:

1. Unless otherwise specified, all piping 3 inches in diameter or larger shall be ductile iron conforming to AWWA C151/A21.51, with flanged joints. Unless otherwise specified, all piping shall be minimum special thickness Class 53 with a minimum rated working pressure of 250 psi for flanged pipe. Pipe wall thickness shall be furnished as required by: AWWA C115 for flanged piping; special thickness Class 53 minimum .
2. The words "Ductile Iron" and the weight and class of pipe shall be plainly marked on each piece of pipe.
3. All flanged sections of pipe shall be made up in strict accordance with AWWA C115 specifications. No field make-up flanges will be allowed unless strictly conforming to AWWA C115 with facing done after turning pipe through flange.
4. Flanged joints shall conform to AWWA C110, C111, and C115 and shall be compatible with ANSI B16.1 Class 125. Flanges shall be ductile iron. Flanged gaskets shall be minimum 1/8-inch full face rubber ring gaskets. Thicker gaskets shall be provided as recommended by the manufacturer to meet joint tolerance. Flange bolts shall be standard zinc-plated steel with hex head and hex nuts for the rated working pressure and installation conditions specified. Flanged bolts and nuts installed in wet wells shall be 316 stainless steel.
5. Flanged fittings shall be of ductile iron with ductile iron flanges. Flanged fittings shall conform to AWWA C110 and ANSI B16.1, as applicable, with a minimum rated working pressure of 150 psi.

6. All ductile iron fittings shall be American, Clow, Griffin, Tyler, U.S. Pipe, or equal. No compact fittings are allowed.
7. Unless otherwise specified, all ductile iron piping and fittings shall be cement mortar lined and asphaltic-coated inside. Cement mortar lining shall be in accordance with AWWA C104. Asphaltic coating shall conform to applicable standards herein for the pipe and fittings. Exterior exposed and interior piping shall be furnished with outside surfaces prepared by abrasive blasting in accordance with NAPF 500C-03. Cleaned surfaces shall then be shop-primed. Shop-priming shall be with one coat of Tnemec N69-1255 Hi-Build Epoxoline primer, or equal, applied to a minimum of 5.0 mils dry thickness. Primer used shall be compatible with proposed finish coats; Contractor shall verify. It is the intent of this specification that all piping, supports, and appurtenances shall be furnished shop-primed, clean, and ready to accept finish painting by Contractor with a minimal amount of surface preparation.
8. Unless otherwise specified, piping and fittings in manholes and wet wells shall be as furnished above for exterior exposed and interior piping.

2.02 VALVES

A. Plug Valves:

1. Shutoff valves in cast or ductile iron lines containing wastewater shall be DeZurik Series PEC or PEF 100% port Eccentric, Valmatic Cam Centric Series, or equal.
2. Valves shall be of the nonlubricated rectangular-ported eccentric type with resilient faced plugs and end connections. The plug profile shall be of a cylindrical eccentric shape so that the vertical face of the plug is straight and the horizontal face is eccentrically curved in relation to the plug shafts. Segmented ball valves with spherical plugs shall not be acceptable. Port areas shall be at least 100% (PEF) or 80% (PEC) through 20 inches and 70% (PEC) for 24 inches and above of full pipe area. Valve bodies shall be of ASTM A126, Class B cast iron. Resilient plug facings shall be of chloroprene or Buna-N, suitable for use with wastewater.
3. Valves shall be furnished with corrosion-resistant seats, replaceable oil-impregnated permanently lubricated 316 stainless steel sleeve-type bearings and grit shaft seals on both upper and lower bearing journals that comply with the latest edition of AWWA C507 and C504. All valves shall include grease fittings on upper and lower journals. Bodies of 3-inch and larger valves shall be furnished with a minimum 1/8-inch-thick machined smooth welded overlay seat of not less than 90% nickel. Seat area shall be raised surface completely covered with weld to ensure that the plug face contacts only nickel. Screwed-in seats are not acceptable. Valve shaft seals for valves 4 inches and

larger shall be of the type utilizing a stuffing box and pull-down packing gland. Shaft seals shall be designed for replacement with the line pressurized at design pressure with the plug in both the open and closed position. For submerged service, or in valve manholes, valve vaults, or underground utility structures, valves shall have stainless steel bolts.

4. The design of the valve and stuffing box assembly shall be such that the packing can be adjusted or completely replaced without disturbing any part of the valve or operator assembly except the packing gland follower. Stuffing boxes shall have a depth sufficient to accept at least four rings of packing. Valve seating adjustment shall be accomplished without removing the valve from the pipe line and with pressure in the line. For lever-operated valves, the plug position retention friction device shall consist of an adjustable phenolic cone that clamps on the plug shaft or a moly sheath. Metal-to-metal friction devices shall not be acceptable.
5. Valve working pressure ratings shall be 175 psi for valves through 12 inches and 150 psi for valves 14 inches through 24 inches. Valves shall provide drip-tight shutoff up to the full pressure rating.
6. All plug valves for buried service, all plug valves 8 inches in diameter or larger, and all plug valves with direct pressure greater than 75 psi or reverse differential pressure greater than 25 psi shall have worm gear actuators. All gearing shall be enclosed in a semisteel housing and be suitable for running in a lubricant with seals provided on all shafts to prevent entry of dirt and water into the actuator. The actuator shaft and the quadrant shall be supported on permanently lubricated bronze bearings. Actuators shall indicate valve position. Buried or submerged valves and valves in manholes shall be supplied with actuators suitable for direct burial or submergence, shall be mounted on a gasketed and totally enclosed actuator mounting bracket, and shall have a totally enclosed and gasketed cover. All other valves shall be furnished with lever actuators. Supply one lever for every four valves furnished. All valves 3 inches and smaller shall have individual levers. Valves not in reach of the floor (7 feet to centerline or greater) shall have chainwheel worm gear actuators. Right angle actuators shall be furnished, if required, because of valve position. Supply sufficient galvanized or electroplated chain with chainwheel so loop through chainwheel is within 3 feet of floor. Buried or submerged service valves shall be supplied with 316 stainless steel bolts and hardware for both valve and actuator.
7. Adjustable valve boxes shall be provided for all buried valves. Valve boxes shall be Tyler/Union 6850 Series, 4 inches through 12 inches, or equal. Extension heights shall be provided as required. Lids shall be marked for appropriate use. Contractor shall verify that all valve boxes are large enough to accommodate all operating nuts and wrenches. The valve box shall be centered and plumb over the wrench nut of the valve with the box cover flush with the finished ground elevation. Solid 4-inch

concrete blocks shall be placed under the base of valve boxes so that the bottom of the base is about 2 inches away from contact with the valve bonnet. The valve box shall not transmit shock or stress to the valve.

8. Extension stems and other accessories shall be provided. Extension stems for quarter-turn plug valves shall be fabricated from 2-inch pipe, and extensions stems for gear-operated valves shall be fabricated from steel or stainless steel rod. Extension stems, stem guides, and related hardware and accessories for submerged valves shall be stainless steel. Stems shall be provided with 2-inch operating nut or other mechanism. Stem guides shall be provided as recommended by the manufacturer. Maximum unsupported length of stem shall be limited to an l/r ratio of 200.
9. Asphaltic varnish and coal tar coating are not allowed on interior valves. Exterior buried valves shall be fusion-bonded epoxy-coated or epoxy-coated. Interior and exterior exposed valves shall be furnished with all surfaces (except galvanized or stainless steel) prepared in accordance with near white grade SSPC Specification No. 10 removing all dirt, rust scale, and foreign materials. Surface preparation shall be done at such time during the assembly process as to preclude damage to the valves once assembled. Cleaned surfaces shall then be shop-primed. Shop-priming shall be with one coat of Tnemec N69-1255 Hi-Build Epoxoline primer, one coat of Tnemec #141 Pota Pox 80 epoxy primer, or equal, applied to a minimum of 5.0 mils dry thickness. Primer used shall be compatible with proposed finish coats; Contractor shall verify. It is the intent of this specification that all valves, supports, and appurtenances shall be furnished shop-primed, clean, and ready to accept finish painting by Contractor with a minimal amount of surface preparation.

B. Check Valves:

1. Check valves shall be GA Industries Figure 230-DS, Apco Model 250 LS by DeZurik, Clow Style 106SL (2 inches to 12 inches) or 259-02 (14 to 12 inches) (outside lever and spring), GA Industries Figure 220-DS, Apco Model 250 LW by DeZurik, Clow Style 106WL (2 to 12 inches) or 159-02 (14 to 30 inches) (lever and weight), or equal, 150 psi, ductile iron or iron body, bronze trimmed, swing check. Two levers and springs, heavier springs, and/or additional weights shall be used if necessary to stop slamming.
2. Asphaltic varnish and coal tar coating are not allowed on check valves. Exterior of cast iron or steel valve body shall be furnished with all surfaces (except galvanized or stainless steel) prepared in accordance with near white grade SSPC Specification No. 10 removing all dirt, rust scale, and foreign materials. Surface preparation shall be done at such time during the assembly process as to preclude damage to the valve once assembled. Cleaned surfaces shall then be shop-primed. Shop-priming shall be with one coat of Tnemec N69-1255 Hi-Build Epoxoline primer, one coat of Tnemec #141 Pota Pox 80 epoxy primer, or equal, applied to a

minimum of 5.0 mils dry thickness. Primer used shall be compatible with proposed finish coats; Contractor shall verify. It is the intent of this specification that all valves, supports, and appurtenances shall be furnished shop-primed, clean, and ready to accept finish painting by Contractor with a minimal amount of surface preparation.

C. Air/Vacuum Release Valves:

1. Automatic air/vacuum release valves shall be combination air valve for wastewater as manufactured by A.R.I., Model D-020, or equal. Valve shall have a working pressure range of 3-250 psi.
2. Valves shall be manufactured with flanged ends with main part of valve constructed of 316 stainless steel. The cover and top of the air valve shall be constructed of 316 stainless steel.

D. Backwater Valves:

1. Backwater valves shall be provided and installed in all building sanitary sewer laterals. The backwater prevention valve shall be located on the inside of basements or crawl spaces and be readily accessible at all times. The backwater prevention valve for buildings located on slabs shall be installed on the building side of the clean out.
2. Valves shall be Clean Check Backwater Valve by Rector Seal, Adapt-a-valve by Mainline Backflow Products, or equal.
3. Valves for buildings located on slabs shall be installed in a water-tight access pit with fitted cover to provide access for maintenance, inspection and cleaning.

E. Cleanouts

1. Cleanouts shall be provided and installed in all building sanitary sewer laterals. The cleanout shall be installed within 10 feet of the building.
2. Cleanouts shall be PVC.

2.03 PIPING APPURTENANCES AND MISCELLANEOUS MATERIALS

- A. General: Piping appurtenances shall be made of the materials specified.
- B. Quick Hose Disconnect: Quick hose disconnect shall be 6-inch stainless steel, F-Adapter type, as manufactured by PT Coupling Co., Inc., Part No. 60F, or equal, with dust cap.
- C. Pipe Coupling: Pipe couplings shall be Dresser Type 38, Smith Blair 411, or equal, steel coupling. Contractor shall provide tie ears and tension ties where necessary to restrain pipe.

- D. Tension Ties: All tension ties, rod ties, and control rods shall be provided to resist a minimum 150 psi pressure in the pipe line. Contractor shall provide tie ears to secure tension rods to flanges where necessary. Rods shall be provided with nuts and washers on both sides of tie ears. All nuts shall be carbon alloy steel conforming to ASTM A563, and washers shall be hardened steel conforming to ASTM F436. Rods shall be ASTM A36 steel at a minimum. Tie rods shall be equally spaced around pipe. The following table lists the minimum number and diameter in inches for the tie rods for various sizes of pipe.

Pipe Size, Inches	150 psi Pressure		250 psi Pressure	
	Minimum Number	Minimum Size, Inches	Minimum Number	Minimum Size, Inches
4-10	4	5/8	4	5/8
12	4	5/8	4	3/4
14	4	3/4	4	7/8
16	4	3/4	4	1
18	4	7/8	4	1-1/8
20	4	1	4	1-1/4
24	4	1-1/8	4	1-1/2
30	4	1-3/8	7	1-3/8
36	8	1-1/4	8	1-1/2
42	12	1-1/8	12	1-1/2
48	11	1-3/8	22	1-1/4
54	11	1-1/2	22	1-3/8

- E. Floor Boxes: Provide floor boxes in concrete floors or slabs as required. Floor boxes shall be Neenah R-7506-B, Clow F-5690, or equal. Contractor shall verify that all floor boxes are large enough to accommodate all operating nuts and wrenches.
- F. Mechanical Seals: Mechanical seals shall be 316 stainless steel Link Seal, or equal. Link seals shall be provided with 316 stainless steel bolts, nuts, and fasteners. Sleeve diameter shall be provided and mechanical seals installed as recommended by the manufacturer.
- G. Pressure Gauges: Provide a pressure gauge on each new pump discharge piping in the valve pit. Pressure gauges shall be Ashcroft, or equal, and shall have scale in psi with a maximum range equal to twice the normal operating pressure indicated in the submersible pump equipment specifications. Gauges shall have 4-inch minimum diameter stainless steel case, shall be connected to a mineral-oil filled diaphragm housing to separate the gauge from liquid in discharge line, and shall have accuracy of $\pm 1\%$. Provide isolation valve and union at connection to pipe to allow the gauges to be removed while the line is under pressure. Gauges shall be mounted to permit pressure readings from above without entering the valve pit.

PART 3–EXECUTION

3.01 INSTALLATION

A. Interior or Exposed Piping:

1. Provide pipe supports for all piping. Pipe support spacing and type shall, at a minimum, conform to manufacturer's recommendations unless more restrictive requirements are specified. All interior or exposed pipelines shall be securely supported by adjustable saddles, brackets, or adjustable hangers supported directly by concrete, masonry work, or tile. Strap hangers, tin clips, or U-hooks will not be acceptable. Piping shall be supported using base fittings and concrete pads to 6 inches above the floor, Anvil 264, B-line, or equal, adjustable pipe saddle stand with floor flange to 6 feet above the floor, and supporting clamps or inserts more than 6 feet above the floor. In general, the maximum spacing of supports shall not exceed 10 feet on centers. Stainless steel supports shall be used in submerged locations and wet wells. Piping shall be adequately supported and braced to resist thrust at bends, rubber expansion joints, and joints. Insulation saddles shall be used at supports of insulated piping. Contractor shall furnish and place hangers, supports, wall pipes, and sleeves in the forms before concrete is poured wherever needed
2. All piping shall be adequately supported and braced to resist thrust at bends and joints. Use base elbows, poured concrete, or rod ties. The weight of the piping shall be supported independently of connected equipment.
3. Exposed piping shall run straight, in neat parallel lines, and shall be located far enough from walls, ceilings, and floors to permit access for covering of pipe and painting work. Care shall be taken in laying out piping so that there is no interference with the proper location of piping for other purposes or other equipment and shall be run with regard to the requirements of each service.
4. On liquids and on lines carrying solids where neither side of the pipeline drains, the valve shall be positioned so that the seat end of the valve is downstream of the shutoff pressure. Where possible in horizontal pipelines, the valve shall be installed with the axis of the plug horizontal and the plug is in the top of the valve when in the open position. In vertical pipelines carrying, the seat end shall be at the top of the valve.

B. Wall and Other Pipe Penetrations:

1. Contractor shall furnish and place hangers, supports, wall pipes, sleeves, and floor boxes in the forms before concrete is poured wherever needed.

2. Where pipes pass through concrete members, Contractor shall provide sleeves in the forms for the piping. The sleeve diameter shall not exceed the pipe O.D. plus 2 inches (or the pipe flange O.D. plus 1 inch as applicable). If the concrete members are to be watertight, the annular space around the pipe shall be sealed with a mechanical seal. Sleeves shall be steel unless noted otherwise and shall include minimum 1-inch waterstop.
3. Where pipe passes through nonwatertight walls, the annular space shall be grouted full. Where pipes pass through nonwatertight floors, the sleeve shall extend 1 inch above the finished floor elevation. The annular space shall remain open, except the annular space between a rated space (example—Class 1, Division 1, Group D hazardous location) and a nonrated space shall be sealed with a mechanical seal.
4. Where pipes pass through a roof, they shall be run through an approved roof penetration with flashing and counter flashing.
5. Where new pipes go through existing watertight concrete members, Contractor shall core a hole through the member. The annular space between the concrete and pipe shall be sealed with a mechanical seal. Where new pipes go through existing nonwatertight concrete or masonry members, holes shall be cored and annular space between the concrete and the pipe shall be grouted full (walls or floors at rated spaces) or remain open (floors at nonrated spaces). Prior to any coring, Contractor shall locate reinforcing steel in the member.
6. Rough openings in wet well walls shall be provided to install force main discharge piping. Opening shall be minimum necessary to provide for nominal adjustments of pipe installation to eliminate the need for special flanges or sleeves in the wet well to allow for laying length adjustments. After piping is installed and properly supported, opening shall be filled with nonshrink grout formed to the wall surfaces.

3.02 FIELD QUALITY CONTROL

- A. All work shall be inspected, tested, and approved in accordance with federal, state, and local rules and regulations. All work shall also be tested as specified in this manual.
- B. Test results shall be recorded, and reports or appropriate certificates shall be submitted to the City in triplicate.

END OF SECTION

SECTION 10

SLOPE PROTECTION AND EROSION CONTROL

PART 1–GENERAL

1.01 SUMMARY

- A. Work Included: Erosion control devices.

1.02 REFERENCES

- A. Indiana Department of Environmental Management requirements as outlined in 327 IAC 15.
- B. City of Seymour requirements as outlined in the MS4 Manual.
- C. Standard Specifications: Unless otherwise indicated, Standard Specifications shall refer to the *State of Indiana Department of Transportation, Standard Specifications, Latest Edition*, including all issued supplemental specifications.

1.03 REGULATORY REQUIREMENTS

- A. For land disturbance greater than one acre, Contractor obtains notice of intent (NOI).
 - 1. Prior to initiating any land disturbance associated with the Work, Contractor shall implement erosion control procedures as required by local ordinance and /or state regulation.
 - 2. Contractor and its subContractors shall execute and sign the following certification:

“I certify under penalty of law that I understand the terms and conditions of the General Pollutant Discharge Elimination System Permit that authorizes the storm water discharges associated with industrial activities from the construction site. I agree to indemnify and hold the City harmless from any claims, demands, suits, causes of action, settlements, fines, or judgments and the costs of litigation, including, but not limited to, reasonable attorneys fees and costs of investigation and arising from a condition, obligation or requirement assumed or to be performed by Contractor for storm water pollution and erosion control.”
 - 3. Contractor shall provide a “qualified” inspector to inspect erosion control and pollution controls. Inspector shall have prior experience with erosion and pollution controls and have knowledge of installation and maintenance of erosion and pollution controls. Inspector shall be identified in the erosion and pollution control plan. In accordance with the General Pollutant Discharge Elimination Systems Permit conditions, the

project site erosion control inspection shall be every seven days and after each one-half-inch rainfall or greater. Contractor shall maintain hard copies of the inspection report with storm water erosion and pollution control plan for the duration of the Project.

4. Contractor shall respond within 24 hours to all corrective measures noted on the inspection report to address pollution issues. Contractor shall submit to the City a written notice stating the times, dates and actions taken to rectify the defective pollution and erosion controls.
5. Contractor shall pay any fines or other fees resulting from failure of Contractor to comply with the permit requirements.

1.05 QUALITY CONTROL

- A. Construct and maintain erosion sediment control measures in accordance with IDEM and the City's requirements.
- B. Check facilities weekly and after any rainfall event, and make needed repairs within 24 hours.

PART 2-PRODUCTS

2.01 EROSION MATS

- A. Uniform web of interlocking wood excelsior fibers, with a net backing on one side. The wood from which the blanket is produced shall have been properly cured to achieve adequately curled and barbed fibers. The blanket shall be of uniform thickness with the wood fibers evenly distributed over the entire area of the blanket. The blanket shall be furnished in rolled strips. The width of the strips shall be 48 inches, ± 1 -inch. Weight of blanket measured under average atmospheric conditions shall be 78 pounds per 80 square yards, $\pm 10\%$. Net backing shall have mesh size not exceeding 1 1/2 by 3 inches and may be woven from twisted paper, cotton cord, a biodegradable plastic, or other alternate approved by the City. The blanket shall be nontoxic to vegetation.

2.02 SILT FENCE

- A. Use geotextile fabric consisting of either woven or nonwoven polyester, polypropylene, stabilized nylon, polyethylene, or polyvinylidene chloride with the following requirements. Fabric shall have the minimum strength values in the weakest principal direction. Nonwoven fabric may be needle punched, heat bonded, resin bonded, or combination thereof.
- B. Furnish geotextile fabric in a wrapping which will protect the fabric from ultraviolet radiation and from abrasion because of shipping and handling. Keep geotextile dry until installed.

2.03 GEOTEXTILE FABRIC

- A. Geotextile for areas below structures and for use at perforated drain pipe trenches shall be Mirafi 140N, or equal.
- B. Geotextile below riprap shall be Mirafi 600X, or equal.
- C. Geotextile below base course shall be Mirafi 500X, or equal.

2.04 RIPRAP

- A. Stone for riprap shall be durable quarry stone of approved quality. It shall be sound, hard, dense, resistant to the action of air and water, and free from seams, cracks, or other structural defects.
- B. Stone for riprap shall be in accordance with Standard Specifications, Section 904 Class 2.

2.05 STRAW BALE BARRIERS

- A. Provide per INDOT Standard Specifications.

PART 3–EXECUTION

3.01 GENERAL

- A. Install devices before construction activities begin.
- B. Proceed carefully with construction adjacent to stream channels to avoid washing, sloughing, or deposition of materials into the stream. If possible, the work area should be diked off and the volume and velocity of water that crosses disturbed areas be reduced by means of planned engineering works (diversion, detention basins, berms).
- C. Expose the smallest practical area of soil at any given time through construction scheduling. Make the duration of such exposure before application of temporary erosion control measures or final revegetation as short as practicable.

3.02 EROSION MAT INSTALLATION

- A. Place erosion mat immediately after seeding or sodding operations have been completed. Before mat placement, remove all material or clods over 1 1/2 inches in diameter and all organic material or other foreign material which interfere with the mat bearing completely on the soil or sod.
- B. Any small stones or clods which prevent contact of the mats with the soil shall be pressed in the soil with a small lawn-type roller or by other effective means. The mat shall have its lateral edge so impressed in the soil as to permit runoff water to flow over it.

- C. The matting strips shall be rolled on or laid in direction of flow. Spread mat evenly, smoothly, in a natural position without stretching and with all parts bearing on soil, and place blanket with netting on top. Overlap adjacent strips at least 4 inches. Overlap strip ends at least 10 inches. Make overlaps with the upgrade section on top.
- D. Bury upgrade end of each strip of fabric or blanket at least 6 inches in a vertical slot cut in the soil and press soil firmly against the embedded fabric or blanket.
- E. Anchor mats in place with vertically driven staples, driven until their tops are flush with the soil. Space staples at 3-foot centers along mat edges and stagger space at 3-foot centers through the center. Place staples at 10-inch centers at end or junction slots.
- F. Reseed areas damaged or destroyed during erosion mat placing operations as specified for original seeding.
- G. Dispose of surplus excavated materials and all stones, clods, or other foreign material removed in the preparation of the seeded soil or sodded surface before placing mat.
- H. Following mat placement, uniformly apply water to the area to moisten seedbed to 2-inch depth and in a manner to avoid erosion.
- I. Maintain erosion mat and make satisfactory repairs of damage from erosion, traffic, fires or other causes until work acceptance.

3.03 GEOTEXTILE FABRIC

- A. Before placing fabric, grade area smooth and remove stones, organic matter, or other foreign material which would interfere with fabric being completely in contact with soil.
- B. Place fabric loosely and lay parallel to direction of water movement. Pinning or stapling is acceptable to hold geotextile in place. Overlap or sew together separate pieces of fabric. Overlap joints a minimum 24 inches in the flow direction. After placement, do not expose fabric more than 48 hours before covering.
- C. Cover damaged areas with a patch of fabric using a 3-foot overlap in all directions.

3.04 SILT FENCE INSTALLATION

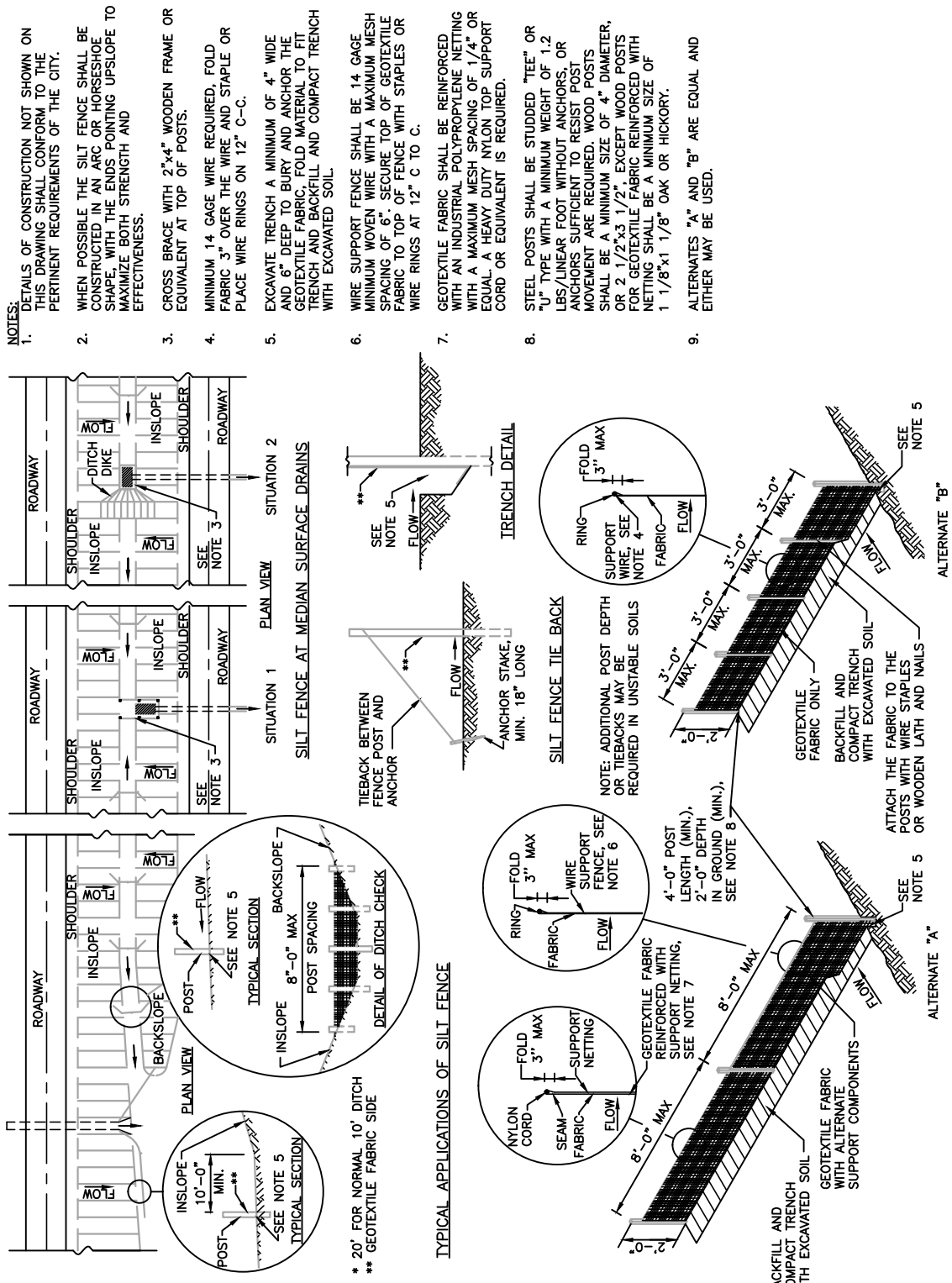
- A. Erect silt fence before starting construction operations which might cause sedimentation or siltation at site of proposed silt fence.
- B. Construct silt fence in an arc or horseshoe shape with ends pointing up slope. Remove silt fences after slopes and ditches have been stabilized and turf developed to the extent that future erosion is unlikely. Dispose of materials remaining after removal.

- C. Inspect all silt fences immediately after each rainfall and at least daily. Correct deficiencies immediately. Where construction activity changes the earth contour and drainage runoff, make a daily review to ensure that silt fences are properly located for effectiveness. Where deficiencies exist, install additional silt fences.
- D. Remove and dispose of sediment deposits. Sediment deposits remaining in place after the silt fence is no longer required shall be dressed to conform with the existing grade and the area topsoiled, fertilized, and seeded as required.

3.05 STRAW BALE BARRIERS

- A. Provide as necessary on ditch lines and other drainageways to minimize construction sediment laden runoff to downstream ditches and channels and into streams.
- B. Inspect all barriers immediately after each rainfall and at least daily. Correct deficiencies immediately. Where construction activity changes the earth contour and drainage runoff, make a daily review to ensure that barriers are properly located for effectiveness. Where deficiencies exist, install additional straw bales.
- C. Remove and dispose of sediment deposits. Sediment deposits remaining in place after the barrier is no longer required shall be dressed to conform with the existing grade and the area topsoiled, fertilized, and seeded as required.

END OF SECTION



- NOTES:**
- DETAILS OF CONSTRUCTION NOT SHOWN ON THIS DRAWING SHALL CONFORM TO THE PERTINENT REQUIREMENTS OF THE CITY.
 - WHEN POSSIBLE THE SILT FENCE SHALL BE CONSTRUCTED IN AN ARC OR HORSESHOE SHAPE, WITH THE ENDS POINTING UPSLOPE TO MAXIMIZE BOTH STRENGTH AND EFFECTIVENESS.
 - CROSS BRACE WITH 2"x4" WOODEN FRAME OR EQUIVALENT AT TOP OF POSTS.
 - MINIMUM 14 GAGE WIRE REQUIRED, FOLD FABRIC 3" OVER THE WIRE AND STAPLE OR PLACE WIRE RINGS ON 12" C-C.
 - EXCAVATE TRENCH A MINIMUM OF 4" WIDE AND 6" DEEP TO BURY AND ANCHOR THE GEOTEXTILE FABRIC, FOLD MATERIAL TO FIT TRENCH AND BACKFILL AND COMPACT TRENCH WITH EXCAVATED SOIL.
 - WIRE SUPPORT FENCE SHALL BE 14 GAGE MINIMUM WOVEN WIRE WITH A MAXIMUM MESH SPACING OF 6". SECURE TOP OF GEOTEXTILE FABRIC TO TOP OF FENCE WITH STAPLES OR WIRE RINGS AT 12" C TO C.
 - GEOTEXTILE FABRIC SHALL BE REINFORCED WITH AN INDUSTRIAL POLYPROPYLENE NETTING WITH A MAXIMUM MESH SPACING OF 1/4" OR EQUAL. A HEAVY DUTY NYLON TOP SUPPORT CORD OR EQUIVALENT IS REQUIRED.
 - STEEL POSTS SHALL BE STUDDED "TEE" OR "U" TYPE WITH A MINIMUM WEIGHT OF 1.2 LBS/LINEAR FOOT WITHOUT ANCHORS, OR ANCHORS SUFFICIENT TO RESIST POST MOVEMENT ARE REQUIRED. WOOD POSTS SHALL BE A MINIMUM SIZE OF 4" DIAMETER, OR 2 1/2"x3 1/2", EXCEPT WOOD POSTS FOR GEOTEXTILE FABRIC REINFORCED WITH NETTING SHALL BE A MINIMUM SIZE OF 1 1/8"x1 1/8" OAK OR HICKORY.
 - ALTERNATES "A" AND "B" ARE EQUAL AND EITHER MAY BE USED.

SILT FENCE
NO SCALE

**SECTION 10
EROSION CONTROL
STANDARD CONSTRUCTION SPECIFICATIONS
SILT FENCE DETAIL
CITY OF SEYMOUR
SEYMOUR, INDIANA**

STRAND ASSOCIATES
FIGURE 10-1
4122.067

SECTION 11
PUMPING STATIONS

PART 1-GENERAL

1.01 SUMMARY

- A. This section includes Specifications for providing a submersible pumping station. The station shall consist of two submersible motor driven wastewater pumps, piping, wet well structure, valve vault, valves, electrical controls and other necessary appurtenances.
- B. Materials of construction for the pumps and related equipment shall be suitable for the environment in which they are to be located
- C. All hardware located in the wet well shall be stainless steel.

1.02 REFERENCES

- A. Pumping station shall be in conformance with requirements of the Indiana Department of Environmental Management and all applicable industry codes and laws.

1.03 GENERAL

- A. All Work shall be inspected, tested, and approved as required by federal, state and local rules and regulations and as specified in this section. Unless otherwise approved in writing before testing begins, all tests shall be witnessed by the City, and others as necessary. Test results shall be recorded and reports or appropriate certificates shall be submitted to the City in triplicate.
- B. All piping shall be tested in accordance with Section 8. All underground piping shall be backfilled or properly secured to avoid damage during testing. Should underground piping fail test, Contractor shall be responsible for removal and replacement of backfill as required. All piping, interior or exposed, shall be subject to test before being covered with insulation, or paint. All piping and appurtenances shall be watertight or airtight and free from visible leaks.
- C. All piping shall be flushed or blown out after installation prior to testing. Contractor shall provide all necessary piping connections, water, air, test pumping equipment, water meter, bulkheads, valves, pressure gauge and other equipment, materials and facilities necessary to complete the specified tests. Contractor shall provide all temporary sectionalizing devices and vents as required for testing.

1.04 SUBMITTALS

- A. Manufacturer's Data: Submit manufacturer's data, specifications, and installation recommendations for each item specified herein.

- B. Submit three paper copies, bound in 3-ring binders, and one PDF copy of the shop drawings and product data.
- C. Provide product data on all equipment and devices specified herein as well as wiring schematics for all systems.

1.05 OPERATION AND MAINTENANCE DATA

- A. Submit three paper copies, bound in 3-ring binders, and one PDF copy of the operation and maintenance data.
- B. Include spare parts data listing, source, and current prices of replacement parts and supplies, recommended maintenance procedures and intervals.

PART 2-PRODUCTS

2.01 ACCESS DOORS

- A. Wet Well and Valve Vault Access: Provide aluminum single/double leaf access doors as manufactured by Bilco, Halliday, or equal. Doors shall be angle frame design. The doors shall include a positive hold open arm with release handle and a tubular stainless steel compression spring operator. Provide doors with flush slam lock with inside handle and removable key wrench. Aluminum doors shall be mill finish. All aluminum surfaces in contact with concrete shall be painted with bitumastic coating as prescribed by door manufacturer. Door hardware shall be stainless steel throughout.
- B. Doors shall be cast into top slab. Contractor shall coordinate location of door to ensure proper clearance between door and pumps and to allow for proper placement of pumps in the wet well.
- C. Doors shall be reinforced for minimum HS-20 loading, if located in a roadway or drive, or 300 pounds per square foot loading in other locations.
- D. Provide stainless steel unistruts, as necessary, attached to doors to mount accessories. Accessories (upper guide holder, cable holder, power and float cable holder, etc.) shall be stainless steel.
- E. Access cover shall be provided with fall through protection consisting of aluminum grating designed to withstand live load of 300 pounds per square foot. Grating shall allow for visual inspection, limited maintenance, and float adjustment while the grate is in place. Grate shall be provided with a permanent hinging system which will lock grate in 90° position once opened. A locking device to prevent unauthorized entry to the confined space shall be provided. Aluminum grating shall be powder coated safety orange.

2.02 SIGNS

- A. Caution Sign: Contractor shall provide caution sign at the entrance to the wet well. Sign shall be fiberglass with black letters on yellow background, Brady

Systems B-120, or equal. Sign shall be mounted on wet well top slab with expansion anchors and shall have the following wording:

CAUTION
DANGEROUS/HAZARDOUS AREA
CONFINED SPACE
DO NOT ENTER WITHOUT
PERMIT, PROPER EQUIPMENT, AND SUPERVISION

2.03 PIPE AND PIPE FITTINGS

- A. Size and Type: All materials shall conform to the size and type called for in the Specifications.
- B. In joining two dissimilar types of pipe, standard fittings shall be used when available.
- C. Iron Pipe and Fittings: Ductile iron pipe and ductile iron fittings conforming to Sections 8 and 9 shall be provided for the pumping station and valve vault. Transition to force main material, if force main is of different material, shall be made downstream of the valve vault using appropriate transition fitting.

2.04 VALVES

- A. Shutoff Valves: shutoff valves shall be plug valves as specified.
- B. Check Valves: check valves shall be swing check valves with outside lever and weight as specified.

2.05 PUMPS

- A. General: The pumps shall be Vaughan Company, Inc. Chopper Pump, or equal meeting the following requirements using constant speed operation
 - 1. Operate at the normal condition within +10% of given capacity at given head, or within +5% of given head at given capacity.
 - 2. While operating under suction head at the normal operating conditions, the pump design shall be such that the pump will operate satisfactorily without cavitation, excessive noise, or vibration when operating at the head specified.
 - 3. Pump motor shall be three phase and have a minimum of three horsepower. The motor shall be large enough not to be overloaded at any point on the design curve for the pump chosen to meet the operating conditions.
 - 4. Be designed to operate in submerged condition in the space allotted.
 - 5. Be vertical, centrifugal wastewater pumps with integral motors designed and assembled by same manufacturer.

6. Be capable of pumping waste solids at heavy consistencies without plugging or dewatering of the solids.
7. Be capable of chopping/macerating solid material as an integral part of the pumping action.
8. Be UL approved for Class 1, Division 1, Group D hazardous locations.

2.06 PUMP RETRIEVAL SYSTEM

- A. The design of the pumps shall be such that the pump unit will be automatically and firmly connected to the discharge piping when lowered into place on its mating discharge connection, permanently installed in the wet well. The pump shall be easily removable for inspection or service, requiring no bolts, nuts or other fasteners to be disconnected, or need for personnel to enter the wet well.
- B. Guide rail system shall consist of two stainless steel guide rails, cast ductile iron pump bracket guide and discharge elbow with mounting feet and Class 125 flanges, an upper stainless steel guide rail mounting bracket and intermediate stainless steel guide brackets every 10 feet.
- C. Alignment of the pump to the discharge connection shall be the result of a simple linear downward motion of the pump unit guided by no less than two stainless steel guide bars. Guide bars shall be of a diameter and wall thickness as recommended by the pump manufacturer.
- D. Pumps shall be fitted with a stainless steel cable of adequate strength to permit raising and lowering of the pumps for inspection or removal. All components shall be of adequate size, length, and strength for the pump being lifted and shall be provided so as to allow cable to be connected to and automatically be wound on a winch.

2.07 PUMP CONSTRUCTION

- A. Casing and Back Pull-Out Plate: The pump casing shall be of volute design, spiraling outward to the 125 lb. flanged centerline discharge. Back pull-out design shall incorporate jacking bolts for accurate adjustment of impeller-to-cutter bar clearance. Casing and backplate shall be ductile iron with all water passages to be smooth, and free of blowholes and imperfections for good flow characteristics. A pressure tap shall be included on or near the discharge flange. Backplate shall include a replaceable Rockwell C 60 steel cutter adjustable for 0.005"-0.015" clearance to cut against the rotating impeller pumpout vanes for removing fiber and debris.
- B. Impeller: Shall be semi-open type with pump out vanes to reduce seal area pressure. Chopping/maceration of materials shall be accomplished by the action of the cupped and sharpened leading edges of the impeller blades moving across the cutter bar at the intake openings, with a maximum set clearance between the impeller and cutter bar of 0.015 to 0.025 inches cold. Impeller shall be cast alloy steel heat treated to minimum Rockwell C 60 and dynamically

balanced. The impeller shall be keyed to the shaft and shall have no axial adjustments and no set screws.

- C. Cutter Bar Plate: Shall be recessed into the pump bowl and shall contain at least two shear bars extending diametrically across the intake opening to within 0.010 to 0.020 inches of the rotating cutter nut tooth, for the purpose of preventing intake opening blockage and wrapping of debris at the shaft area. Chopper pumps utilizing individually mounted shear bars shall not be acceptable. Cutter bar shall be alloy steel heat-treated to minimum Rockwell C 60.
- D. Cutter Nut: The impeller shall be secured to the shaft using a cutter nut, designed to cut stringy materials and prevent binding using a raised, rotating cutter tooth. The cutter nut shall be cast steel heat treated to minimum Rockwell C 60.
- E. Upper Cutter: Shall be threaded into the back pull-out adapter plate behind the impeller, designed to cut against the pump-out vanes and the impeller hub, reducing and removing stringy materials from the mechanical seal area. Upper cutter shall be cast steel heat treated to minimum Rockwell C 60. The upper cutter teeth shall be positioned as closely as possible to the center of shaft rotation to minimize cutting torque and nuisance motor tripping. The ratio of upper cutter cutting diameter to shaft diameter in the upper cutter area of the pump shall be 3.0 or less.
- F. Shafting: Pump shafting shall be heat-treated alloy steel. The pump shaft shall directly couple to the motor shaft, with a bolt and keyway.
- G. Submersible Electric Motor: Shall be U/L LISTED EXPLOSION PROOF for Class 1, Group D, Division 1 hazardous locations, with a 1.15 service factor and Class F insulation. Motor shall be equipped with tandem independently mounted mechanical seals in oil bath and with dual moisture sensing probes. The inner and outer seals shall be separated by an oil-filled chamber. The oil chamber shall act as a barrier to trap moisture and provide sufficient time for a planned shutdown. The oil shall also provide lubrication to the internal seal. The inner seal shall be a standard UL listed John Crane Type 21 or equal, with carbon rotating faces and ceramic stationary faces. The outer seal construction shall be designed for easy replacement. Outer mechanical seal shall be 316 stainless steel metal bellows type with silicon carbide or tungsten carbide faces. Seal shall be positively driven by set screws. Elastomers shall be of Viton. Motor shall include two normally closed automatic resetting thermostats connected in series and imbedded in adjoining phases. Motor frame shall be cast iron, and all hardware and shaft shall be stainless steel.
- H. Stainless Steel Nameplates: Shall be attached to the pump and drive motor giving the manufacturer's model and serial number, rated capacity, head, speed and all pertinent data.
- I. Anchor Bolts: Contractor shall provide anchor bolts necessary for equipment furnished. Anchor bolts shall be stainless steel and be of ample strength for the intended service.

- J. Surface Preparation: SSPC-SP5 commercial sandblast, primed with 3 mil minimum dry film thickness zinc-filled primer and finish coated with 3 mil minimum dry film thickness epoxy.

2.08 EQUIPMENT ENCLOSURES

- A. New enclosures shall be front access only, minimum No. 12 gauge stainless steel, continuous hinged doors, rotating lockable handle 3-point latch on each equipment compartment door (not screws or bolts) with top and bottom bolts actuated by one rotating handle on large doors. Quick opening hasps may be substituted for rotating lockable handle latch where approved by City. Panels shall include door stop kit, data pockets for panel wiring diagrams and minimum 18-inch fluorescent light and switch. Panels shall include non-fused, main disconnect with interlock to prevent opening the panel with switch in "On" position. A defeater shall be provided to bypass this interlock, with handle lockable in "Off" position. Interior painting shall include phosphate treatment, zinc chromate iron oxide primer with baked rust inhibiting enamel. Color to be white except as otherwise specified by the City. All doors and panels shall be gasketed, and panels installed outdoors or nonconditioned spaces shall be insulated. All louvers shall be filtered with forced air cooling as necessary by the supplier for conditions where installed. Enclosure rating shall be as follows.
 - 1. Indoor and/or dry locations: NEMA 12, stainless steel.
 - 2. Corrosive and/or damp locations including outdoor locations: NEMA 4X, stainless steel.
 - 3. Hazardous locations: NEMA 7, cast iron.
- B. The equipment mounted within the enclosures shall be mounted on the enclosure back panel, neatly organized, and shall be in accordance with the manufacturer's recommendations. For panels requiring a NEMA 4X enclosure, indicating and control devices shall be mounted on a swing-out inner door.
 - 1. All wiring within control panels shall be insulation-type MTW, minimum size 16 AWG. Wiring within the enclosure shall be routed through plastic wiring troughs with removable covers. Maximum fill for wiring troughs shall be 60%. Terminal strips located adjacent to wiring troughs shall have a minimum of 2-inches between terminal strip and trough. All wiring in control panels not in wiring troughs shall be bound with continuous-type spiral windings.
 - 2. All I/O devices shall be wired to rail mounted terminal blocks. Plastic wiring duct shall be Electrovert "Electro-duct," Panduit, or equal. Terminal blocks shall be Electrovert 9700 Series, Square D, Class 9080 Type G, or equal.
 - 3. Field wiring in dry locations shall be insulation-type THHN, minimum size 14 AWG. Field wiring in damp or wet locations shall be insulation type XHHW-2, minimum size 14 AWG. All field wiring shall terminate at rail mounted terminal blocks. Field wiring terminals shall be clearly identified

as to which I/O terminals they are wired. Wire markers shall be permanently attached, wraparound adhesive, or heat-shrink type markers. Wire numbering preprinted on the conductor and individual wraparound numbers are not acceptable.

4. Jumpers between adjacent terminal blocks shall be copper jumper bars supplied by the terminal block manufacturer.
 5. All panels with DIN rail mounted equipment shall include a minimum of 25% spare DIN rail space.
 6. In addition to spare I/O specified herein, provide a minimum of 25% spare hot and neutral terminals, wired to terminal strips. Spare terminals shall be provided for all voltage sources within the panel (e.g. 120V, 24V).
- C. All wiring for new panels shall be done in the factory, Class II, Type C with master terminal strips for exterior connections. Terminal blocks shall be mounted either at the bottom or on the side of the enclosure, depending where the I/O conduits penetrate the enclosure. Splices are not allowed within enclosures or wireways. All enclosures must pass through doors to point of installation, and if enclosures are shipped in sections, all wiring and connections between sections shall be done by Contractor. All wiring shall be labeled at each end with corresponding numbers. This numbering shall be shown on the shop and record drawings.
- D. All door-mounted devices shall be furnished flush-mounted, and an exterior engraved phenolic nameplate worded by the manufacturer and reviewed by the City (upon receipt of shop drawings) shall be provided for each compartment, device, light, etc. All components within the enclosures shall be identified with interior mounted engraved labels. Labels shall be installed on the enclosure back-panel and not on the device or wireway. Devices shall be grouped for each device or unit being controlled.
- E. Equipment enclosures that include motor controllers shall have disconnects for the enclosure.

2.09 COMMON REQUIREMENTS ALL EQUIPMENT

- A. All indicating and recording devices shall be electric or electronic.
- B. Power supplies shall be protected against short circuits and contain their own overcurrent and overvoltage protection. 12 and 24 VDC power supplies shall be provided and installed in the enclosures for powering all analog input signals where required.
- C. All motor control power shall be 120 volt with suitable circuit protection fuses or breakers. Fuse holders shall be provided with integral LEDs to indicate when the fuse is blown.

- D. Devices powered at 120 volts from control panels shall be fused. This shall include, but not be limited to, solenoid valves, motor operated valves, motorized ball valves, flow meters, scales, transducers, etc.
- E. Each panel shall have a GFI, duplex, 20 ampere, 120 volt receptacle.
- F. If enclosure and panel space is needed for future installation of devices, SCADA, lights, etc., the enclosure and panel shall be constructed for such installation. Supports shall be provided for future equipment, and panel openings shall be made and covered with neat cover plates matching the panel.
- G. Contractor shall furnish one complete extra set of fuses and similar parts which may need replacement in normal service, and an identification list of all component parts and where they may be obtained.
- H. All internal wiring shall be color coded and numbered, and each wire shall be terminated on terminal strips. Schematic and wiring layout drawings, following JIC standards, which show all connections to external devices, a complete bill of materials, interior and exterior panel layouts, and a detailed description of operation shall be submitted for each control panel.
- I. A condensation heater shall be provided in all control panels located outdoors. Condensation heater shall be as manufactured by Hoffman, Model D-AH, X000 Series, sized as required.
- J. The "Hand" mode for all "Hand-Off-Auto" selector switches shall be hardwired directly to the associated motor starter completely bypassing any PLC or controller.
- K. Contractor shall provide new floats in each wet well. Floats shall be mounted on a stainless steel cable with a PVC-covered weight. Float switches shall have the following minimum requirements.
 - 1. The float switches shall consist of a 316 type stainless steel housing 5 1/2 inches in diameter, mounting clamp, and a flexible two-conductor cable with a CPE jacket and a potted SPST magnetic reed switch. Provide switch configuration (NO or NC) as required. The electrical load for the switch contacts shall be 100 VA at up to 250 volts. The two-conductor cable shall be 16 AWG with fine strands made for heavy flexing service and underwater use. Cable length shall be a continuous run to the terminating control panel. A green grounding wire shall connect internally to the float housing. Floats shall be US Filter Model 9G-EF, or equal.
 - 2. Weight and buoyancy shall be such that contaminants will not result in the float switch changing operating level more than 1 inch.
 - 3. Operating temperature range shall be -31° to 194°F.
 - 4. Floats shall be mounted per manufacturer's instructions. All mounting hardware shall be stainless steel and furnished with floats.

5. Provide stainless steel kellum grips for each float cable.
6. Float Controls:
 - a. Both Pumps "Off."
 - b. Lead Pump "On."
 - c. Lag Pump "On."
 - d. High Water.
 - e. Low Water (future).
7. Provide automatic alternator.
8. Provide interface relays and contacts for the following points in the control panel. All points shall be wired and labeled at terminal strips in the panel for connection to a future SCADA System.
 - a. WET WELL HIGH WATER LEVEL (Local indication Red)*
 - b. WET WELL LOW WATER LEVEL (Future) (Local indication Red)*
 - c. PUMP NO. 1 "RUN" (Local indication Green)
 - d. PUMP NO. 2 "RUN" (Local indication Green)
 - e. PUMP NO. 1 "SEAL FAIL" (Local indication Amber)
 - f. PUMP NO. 2 "SEAL FAIL" (Local indication Amber)
 - g. PUMP NO. 1 "OVERTEMPERATURE" (Local indication Red)*+
 - h. PUMP NO. 2 "OVERTEMPERATURE" (Local indication Red)*+

* These alarms will activate the common alarm light. Alarm light shall remain activated until the alarm condition clears. Alarm light is located on the exterior of the enclosure.

+ Alarm signal to the future SCADA System for each pump shall be a common alarm from the call-to-run fail logic, starter overload, and the motor thermostats (overtemperature).

- P. Provide 20A, 120 volt circuit breakers for the following:
 1. Enclosure receptacles, if required.
 2. Lighting, if required.
- Q. Provide alarm light and alarm horn.
- R. Contractor shall install telemetry system as shown in Figure 11-7. Manufacturer's shop drawings shall be submitted to the City for approval prior to manufacturer and installation of the telemetry system. After installation, City will inspect the telemetry system for final acceptance. Prior to this final acceptance, Contractor shall make City requested changes to the telemetry system at no cost to the City.

2.10 CONTROL PANEL DEVICES

- A. Molded case thermal-magnetic circuit breakers shall include integral thermal and instantaneous magnetic trip in each pole. Motor controllers shall include molded

case circuit breakers with integral thermal and instantaneous magnetic trip in each pole. Nonfusible switch assemblies shall consist of quick-make, quick-break load interrupter enclosed knife switch with externally operable handle.

- B. Pushbuttons: Heavy-duty, oil-tight.
- C. Indicating Lights: Heavy-duty, oil-tight, LED, push-to-test type.
- D. Selector Switches: Heavy-duty, oil-tight.
- E. General Purpose Relays: UL Listed with On-Off flag-type or LED indicator.
- F. Timing Relays: UL Listed with On and Timing Out LEDs.
- G. Contactors: All contactors for starters shall be NEMA rated. IEC contactors are not allowed. Contactors shall be Allen Bradley, Bulletin 509, or equal.
- H. Elapsed Time Meters: Redington/Engler 722 series, 3 inches round, flush door mounted, capable of reading up to 99,999.9 hours, nonreset type.

2.11 ELECTROMAGNETIC FLOW METER

- A. The pumping station shall be equipped with an electromagnetic flow meter with remote transmitter. The flow meter shall be Endress + Hauser, Siemens, or equal.
- B. Flow meter sensor shall be NEMA 6P.
- C. Remote transmitter shall be NEMA 4X.

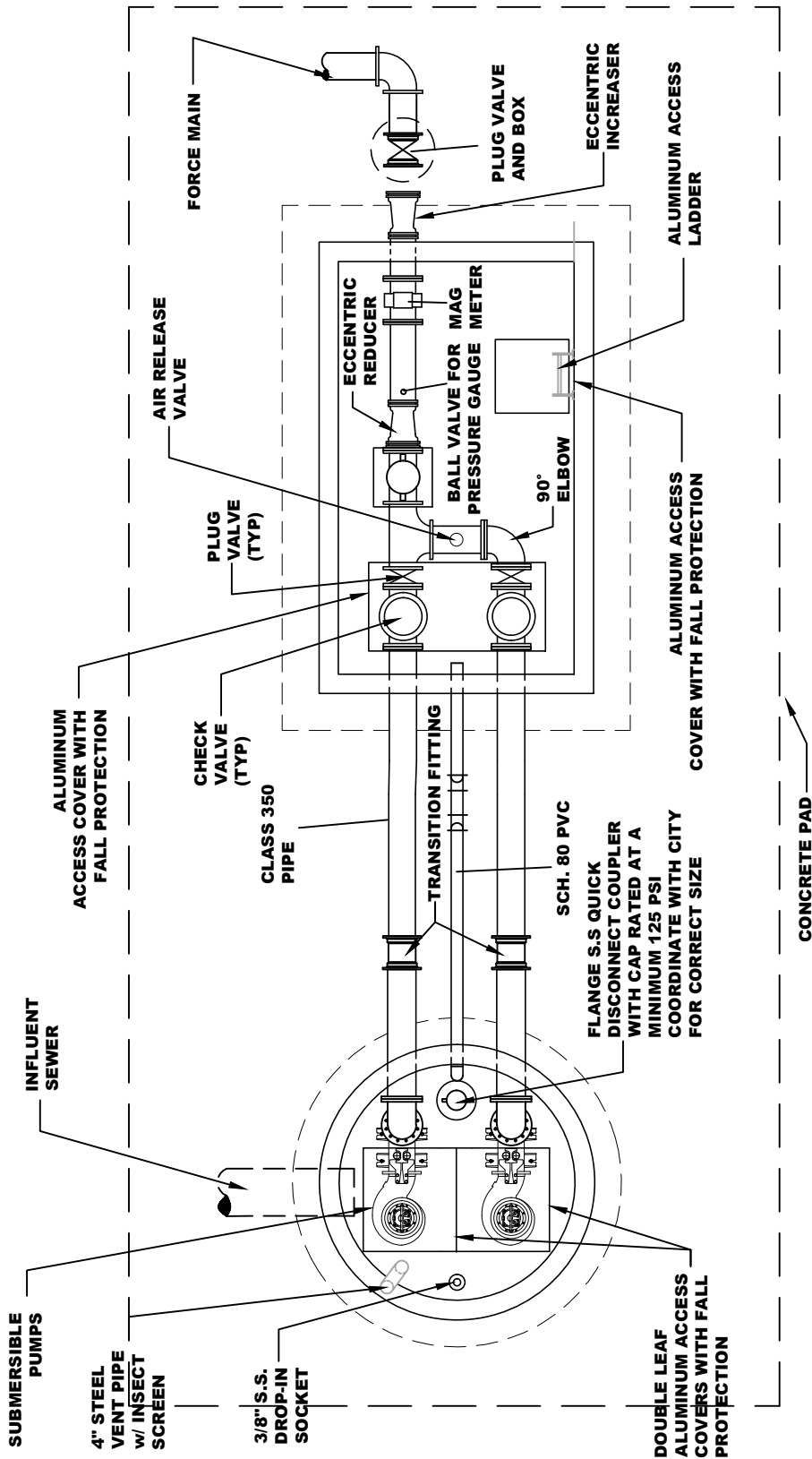
PART 3-EXECUTION

3.01 INSTALLATION OF PIPE AND APPURTENANCES

- A. Interior or Exposed Piping: Provide pipe supports for all piping. All interior or exposed pipelines shall be securely supported by adjustable saddles, brackets, or adjustable hangers supported directly by concrete, masonry work or tile. Strap hangers, tin clips or U-hooks will not be acceptable. Piping shall be supported, using base fittings and concrete pads to 6 inches above the floor, Grinnell 264, B-line, or equal adjustable pipe saddle stand with floor flange to 6 feet above the floor, and supporting clamps or inserts more than 6 feet above the floor. In general the maximum spacing of supports shall not exceed ten feet on centers. Except as specified for plumbing system, all PVC piping shall be supported using galvanized supports for flexible piping. Maximum spacing shall not exceed 5-feet on centers. Piping shall be adequately supported and braced to resist thrust at bends and joints. Plumbing system shall be installed with hangers and supports in accordance with the Plumbing Code. Contractor shall furnish and place hangers, supports, wall pipes and sleeves in the forms before concrete is poured wherever needed.

- B. All piping shall be adequately supported and braced to resist thrust at bends and joints. Use base elbows, poured concrete or rod ties. The weight of the piping shall be supported independently of connected equipment.
 - C. Underground Piping: Underground piping shall be installed as specified in Section 8.
- 3.02 SPARE PUMP: Contractor shall provide a spare, back up pump to the City for each new pumping station. Pump shall be of the same manufacturer, type, and size as the pumps installed in the pumping station.
- 3.03 PUMP TEST AT START UP: The pump manufacturer shall perform the following inspections and tests on each pump at start up:
- A. Impeller, motor rating and electrical connections shall first be checked for compliance with the Specifications.
 - B. A motor and cable insulation test for moisture content or insulation defects.
 - C. Verify correct rotation.
 - D. Verify proper voltage.
 - E. Verify proper current draw in each phase.
 - F. Verify thermal sensor trip will shut down motor in hand and auto mode.
- 3.04 PUMP WARRANTY: The pump manufacturer shall warrant the units being supplied against defects in workmanship and materials for a period of 5 years or 10,000 hours under normal use, operation and service. The warranty shall be in printed form and apply to all similar units. The warranty shall not start until the equipment has been placed in operation for beneficial use as determined by the City.

END OF SECTION

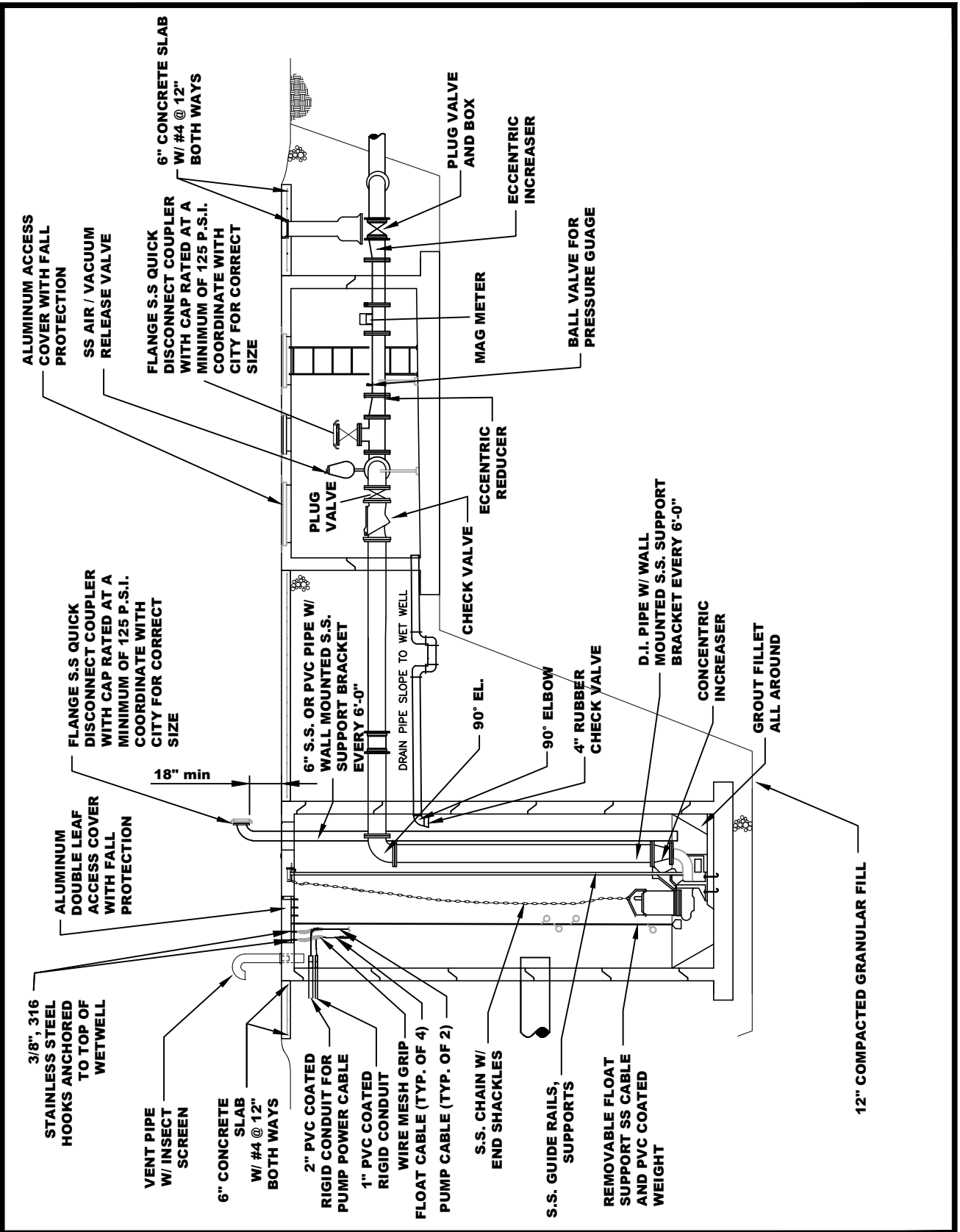


NOTE:
 IF APPROVED BY THE CITY, VALVE VAULT CAN BE PRECAST
 MANHOLE SIZED TO ACCOMMODATE ALL PIPING, VALVES, MAG
 METER, ECT.

**SECTION 11
 PUMPING STATIONS
 STANDARD CONSTRUCTION SPECIFICATIONS
 PUMPING STATION AND VALVE PIT PIPING
 CITY OF SEYMOUR
 SEYMOUR, INDIANA**

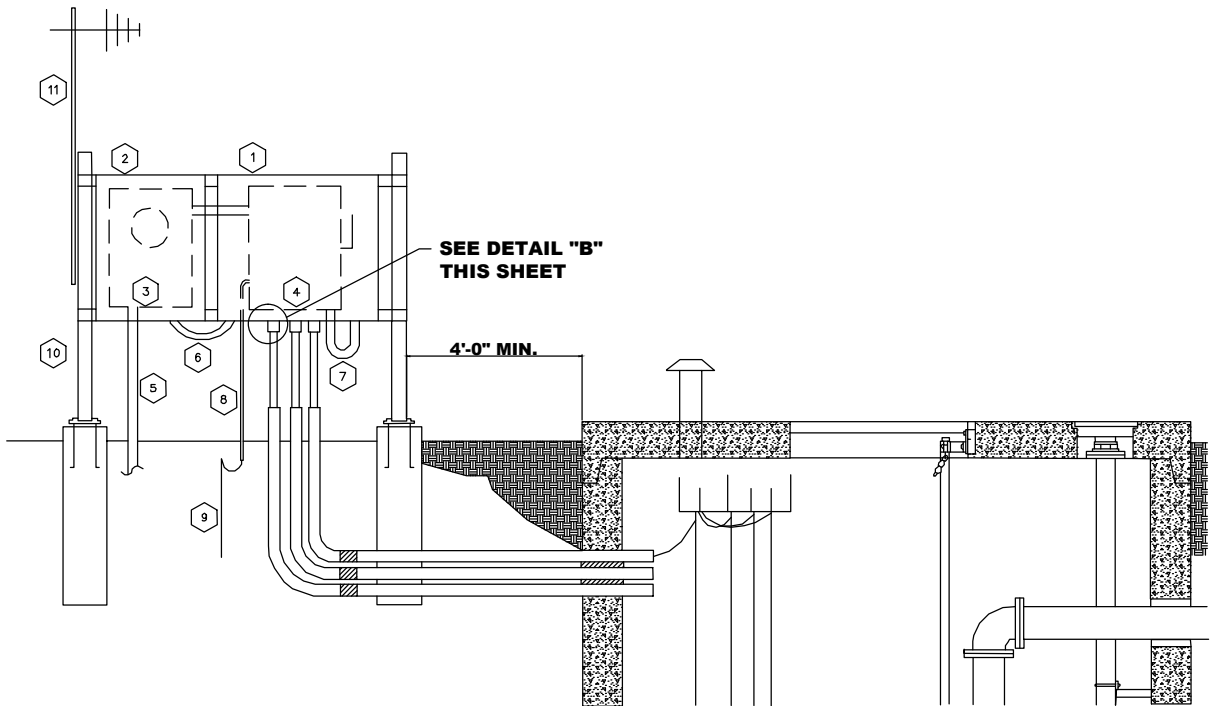


FIGURE 11-1



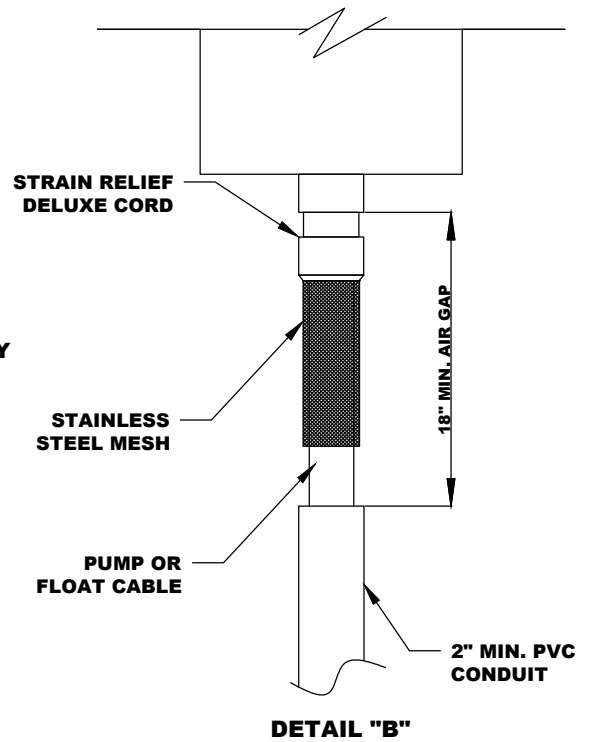
SECTION 11
PUMPING STATIONS
STANDARD CONSTRUCTION SPECIFICATIONS
PUMPING STATION AND VALVE PIT PIPING
CITY OF SEYMOUR
SEYMOUR, INDIANA

STRAND
 ASSOCIATES®
FIGURE 11-2
 4122.067



TYPICAL PUMPING STATION ELECTRICAL

- ① **PUMP CONTROL PANEL**
- ② **SCADA PANEL (BY SCADA CONTRACTOR)**
- ③ **NEW METER BASE MOUNTED ON BACK**
- ④ **NEW FUSEABLE SERVICE DISCONNECT MOUNTED ON BACK**
- ⑤ **SERVICE ENTRANCE AS REQ'D. BY ELECTRIC UTILITY**
- ⑥ **1" SEAL TITE CONDUIT**
- ⑦ **SEAL TITE CONDUIT SIZE PER NEC**
- ⑧ **3/4" CONDUIT WITH #6**
- ⑨ **5/8" X 10' GROUND ROD**
- ⑩ **PANEL SUPPORT - SEE DETAIL E-3, THIS SHEET**
- ⑪ **SCADA ANTENNA ON 1 1/4" ALUMINUM CONDUIT**



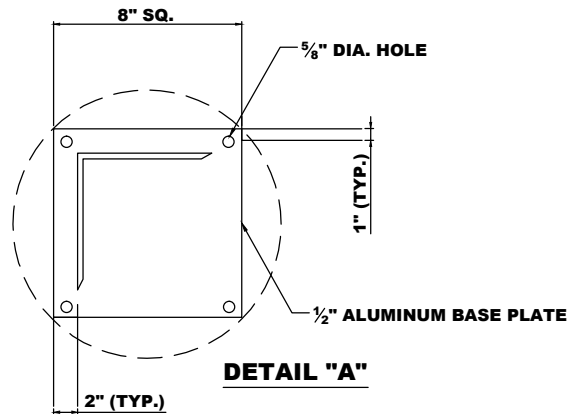
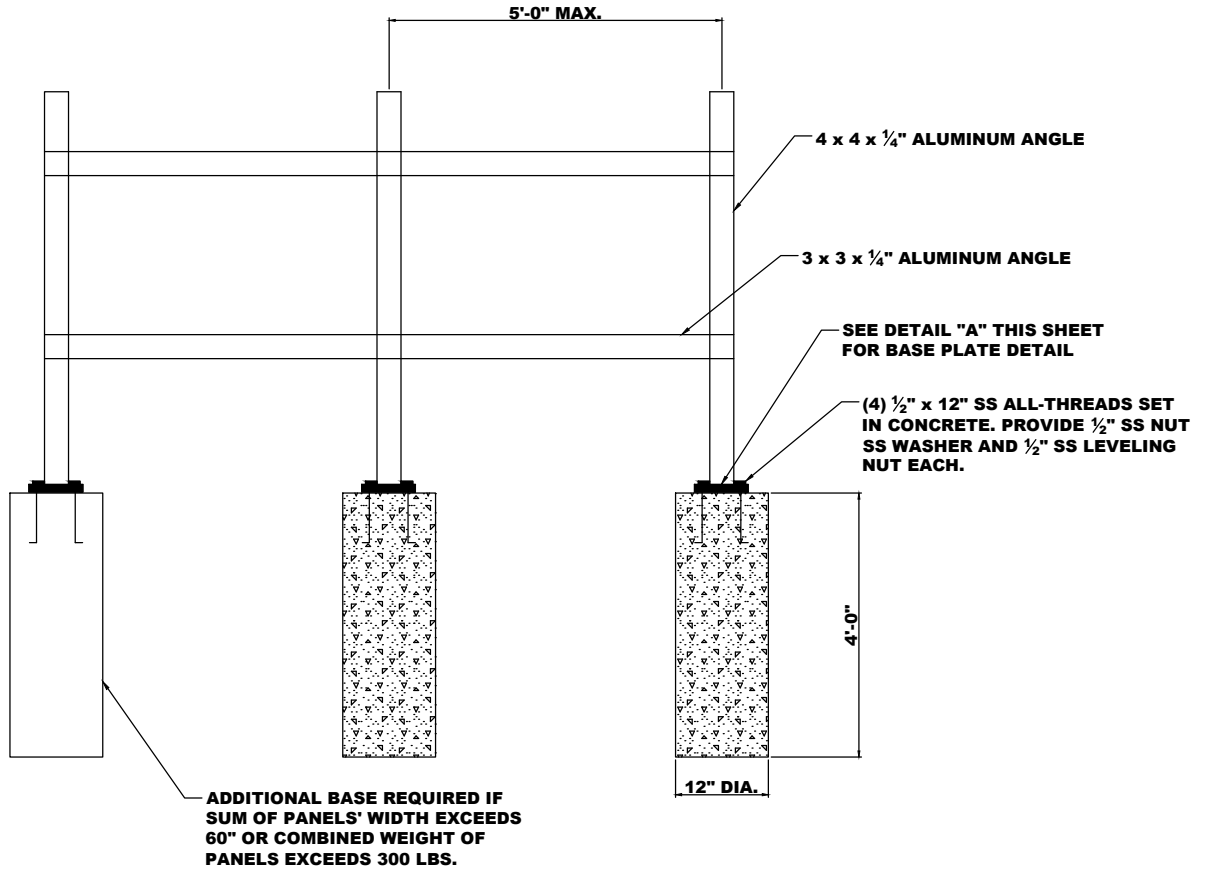
SECTION 11
PUMPING STATIONS
STANDARD CONSTRUCTION SPECIFICATIONS
TYPICAL PUMPING STATION ELECTRICAL INSTALLATION
CITY OF SEYMOUR
SEYMOUR, INDIANA



FIGURE 11-3

GENERAL ELECTRICAL NOTES

- 1 - ALL WORK SHALL COMPLY WITH THE NEC AND INDIANA ELECTRICAL CODE, CURRENT EDITION.
- 2 - ALL UNDERGROUND CONDUIT SHALL BE SCHEDULE 80 PVC, UNLESS OTHERWISE NOTED.
- 3 - SEAL ALL CONDUIT ENTRANCE TO PANELS AND ENCLOSURES WITH 100% CLEAR SILICONE.
- 4 - ALL OUTDOOR FASTENERS SHALL BE STAINLESS STEEL.



OUTDOOR PANEL SUPPORT

File: S:\COL\4100--4199\4122\067\Acad\Outdoor Panel Support Details.dwg Time: Feb 04, 2014 - 9:46am

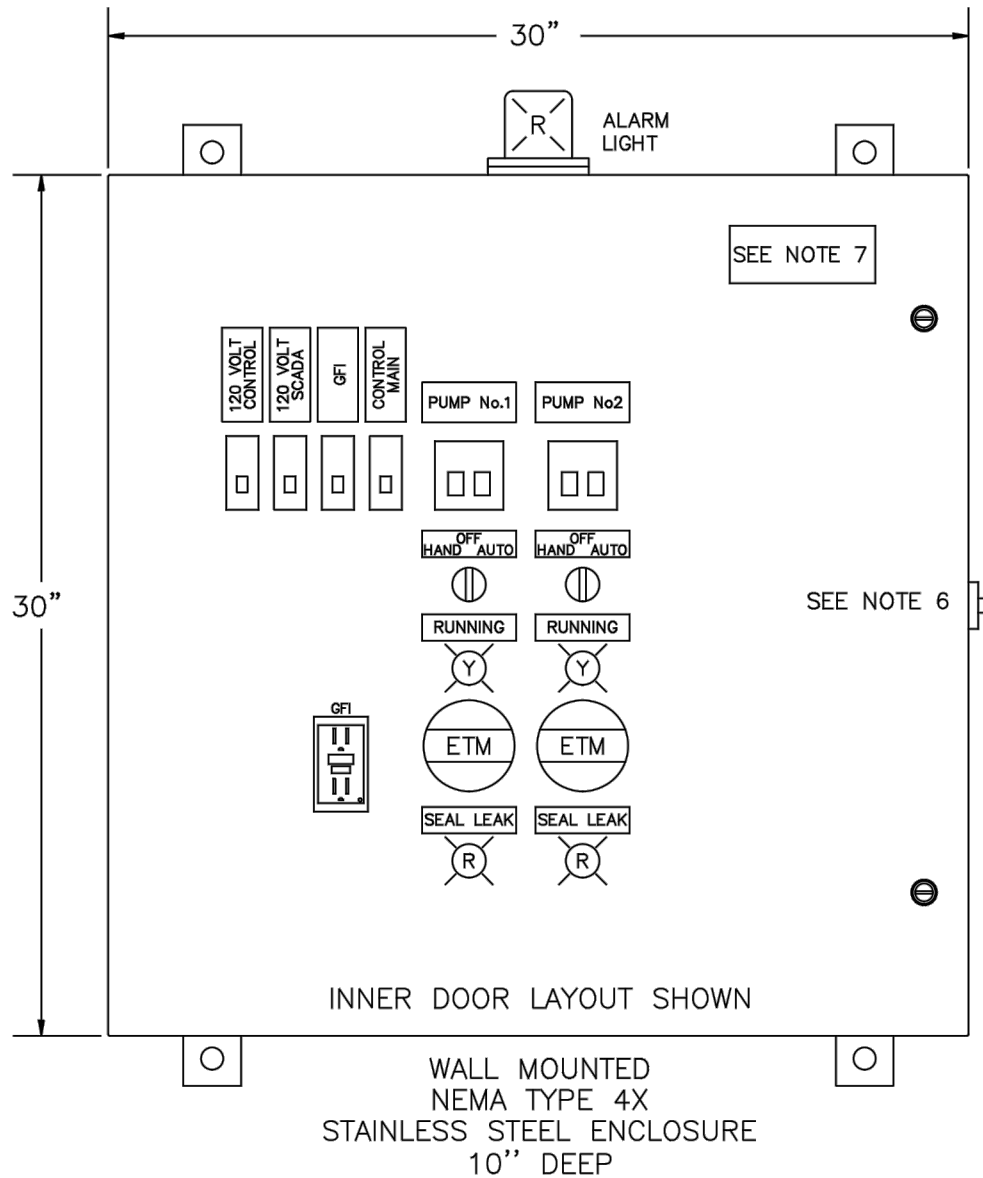
SECTION 11
PUMPING STATIONS
STANDARD CONSTRUCTION SPECIFICATIONS
OUTDOOR PANEL SUPPORT DETAILS
CITY OF SEYMOUR
SEYMOUR, INDIANA



FIGURE 11-4

4122.067

File: S:\COL\4100--4199\4122\067\Acad\Control Panel Dwgs - Control Works.dwg Time: Feb 04, 2014 - 9:46am



- 6.) HASP AND STAPLE PROVIDED ON OUTER DOOR OF ENCLOSURE FOR PADLOCK.
- 7.) WARNING LABEL TO BE YELLOW BACKGROUND WITH BLACK LETTERS. "WARNING - LOCK OUT ELECTRICAL SERVICE TO THIS ENCLOSURE BEFORE OPENING DOOR OR SERVICING EQUIPMENT".

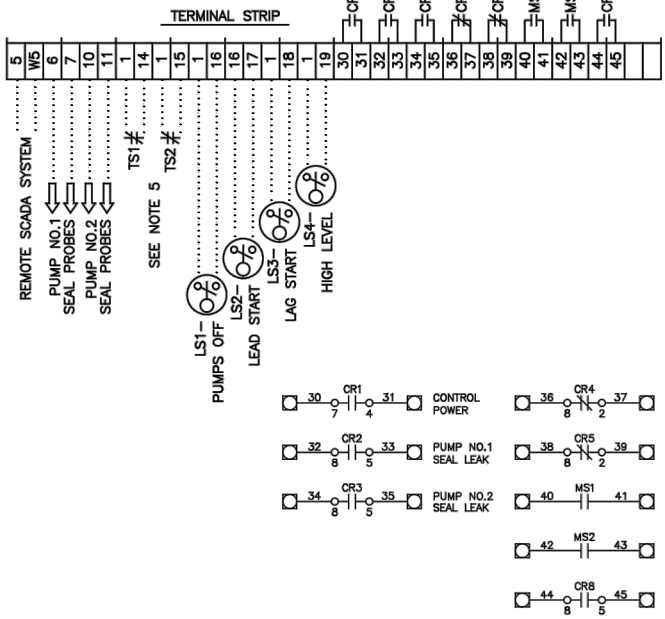
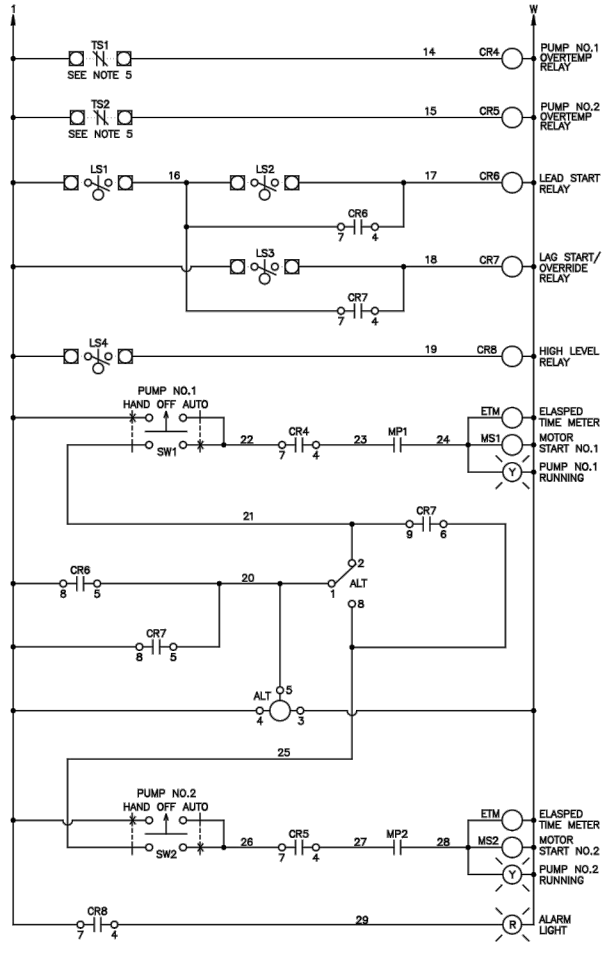
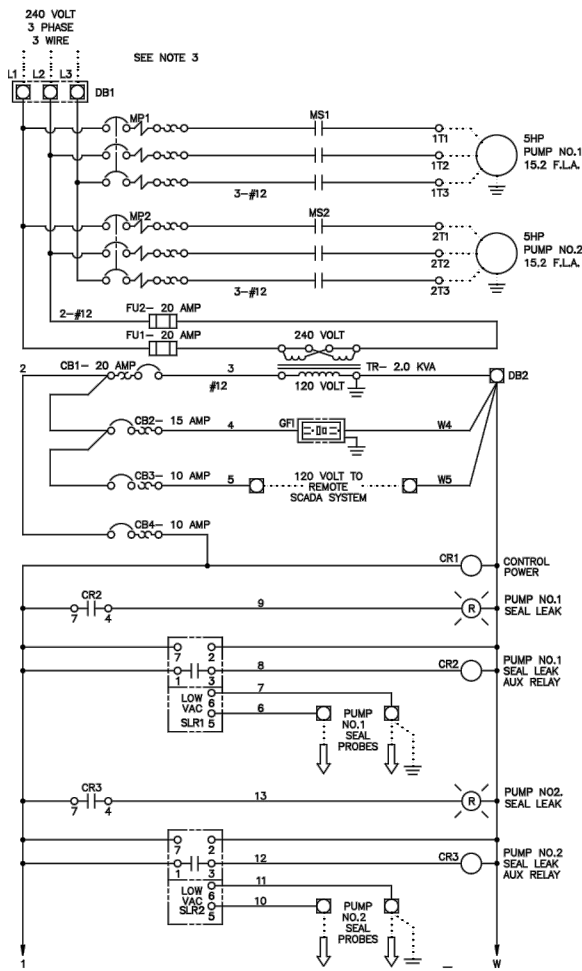
NOTE: INFORMATION ON THIS SHEET IS SHOWN FOR EXAMPLE ONLY. MANUFACTURER SHOP DRAWINGS SHALL BE SUBMITTED TO THE CITY FOR APPROVAL.

SECTION 11
PUMPING STATIONS
STANDARD CONSTRUCTION SPECIFICATIONS
TYPICAL CONTROL PANEL
CITY OF SEYMOUR
SEYMOUR, INDIANA



FIGURE 11-5

4122.067



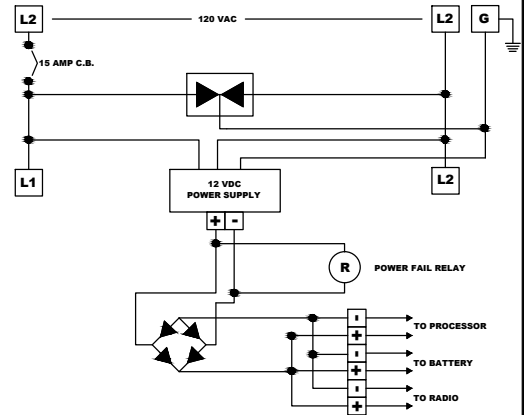
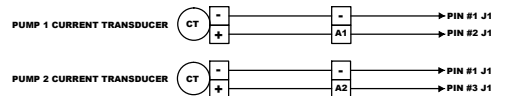
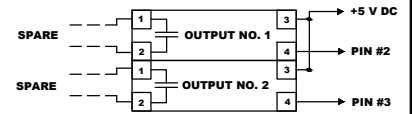
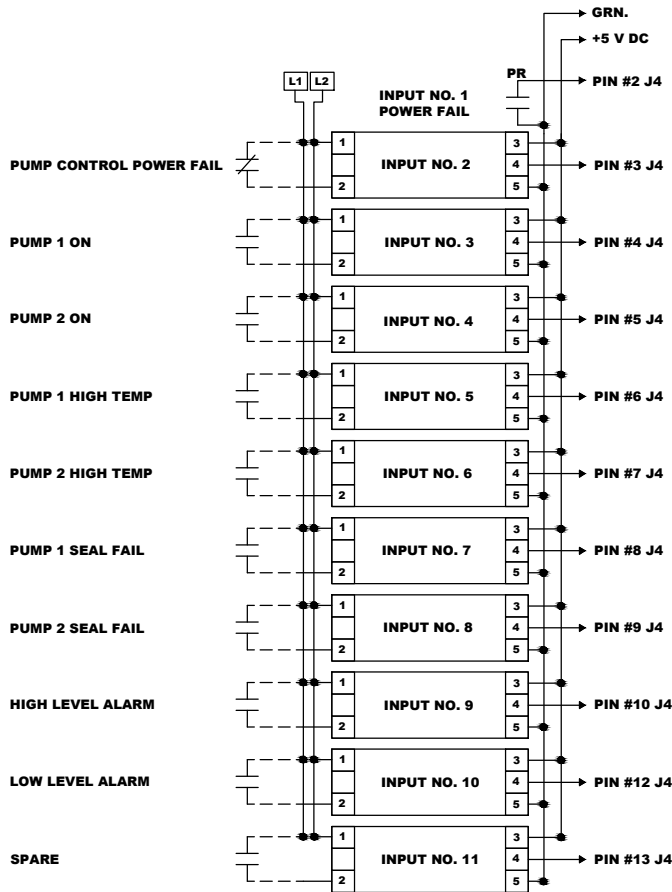
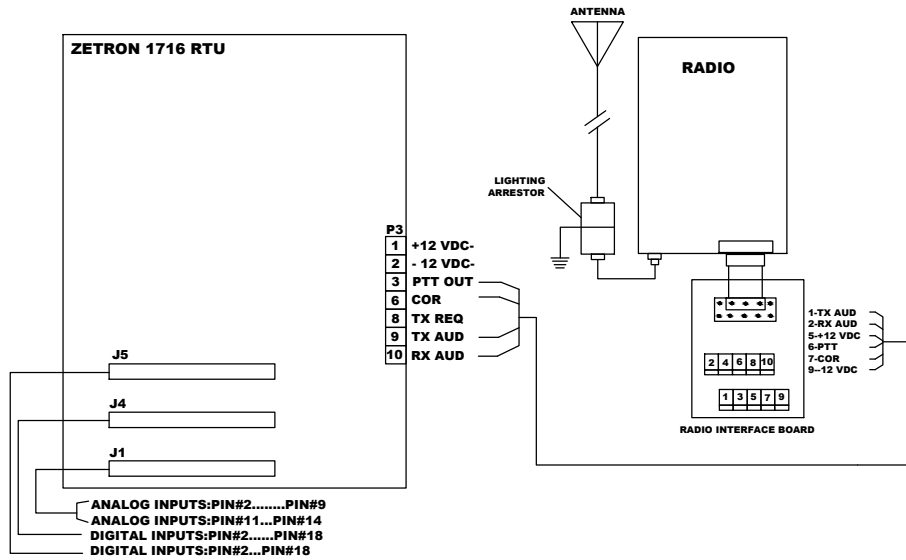
- NOTES:**
- 1.) PANEL GROUND TERMINAL MUST BE CONNECTED TO EARTH GROUND PER NEC.
 - 2.) FACTORY WIRING IS SHOWN _____
FIELD WIRING IS SHOWN
 - 3.) INSTALLER MUST PROVIDE: EITHER A 70 AMP MAXIMUM INVERSE TIME MAIN CIRCUIT BREAKER, OR 60 AMP MAXIMUM DUAL ELEMENT FUSES IN A MAIN DISCONNECTING DEVICE.
 - 4.) RECOMMENDED TIGHTENING TORQUES FOR TERMINALS 240 VOLT POWER 40 POUND INCHES. 120 VOLT POWER, CONTROL & LOW VOLTAGE - 18 POUND INCHES.
 - 5.) THERMAL SAFETY SWITCH (TS) CONTACTS ARE NOT IN ALL MOTORS. IF MOTOR DOES NOT HAVE SWITCH, THESE TERMINALS MUST BE JUMPERED.
 - 6.) HASP AND STAPLE PROVIDED ON OUTER DOOR OF ENCLOSURE FOR PADLOCK.
 - 7.) WARNING LABEL TO BE YELLOW BACKGROUND WITH BLACK LETTERS. "WARNING - LOCK OUT ELECTRICAL SERVICE TO THIS ENCLOSURE BEFORE OPENING DOOR OR SERVICING EQUIPMENT".

NOTE: INFORMATION ON THIS SHEET IS SHOWN FOR EXAMPLE ONLY. MANUFACTURER SHOP DRAWINGS SHALL BE SUBMITTED TO THE CITY FOR APPROVAL.

**SECTION 11
PUMPING STATIONS
STANDARD CONSTRUCTION SPECIFICATIONS
TYPICAL CONTROL PANEL WIRING DIAGRAM
CITY OF SEYMOUR
SEYMOUR, INDIANA**

FIGURE 11-6
4122.067

File: S:\COL\4100--4199\4122\067\Acad\Typical SCADA RTU Details.dwg Time: Feb 04, 2014 - 9:46am



NOTE: INFORMATION ON THIS SHEET IS SHOWN FOR EXAMPLE ONLY. MANUFACTURER SHOP DRAWINGS SHALL BE SUBMITTED TO THE CITY FOR APPROVAL.

SECTION 11
PUMPING STATIONS
STANDARD CONSTRUCTION SPECIFICATIONS
TYPICAL SCADA RTU DETAILS
CITY OF SEYMOUR
SEYMOUR, INDIANA



FIGURE 11-7

SECTION 12
CHAIN LINK FENCE

PART 1–GENERAL

1.01 SUMMARY

- A. Work includes providing all chain link fencing and gates.
- B. All pumping stations shall have a chain link fence installed along the property line to provide for security. Gates shall be installed at the driveway to provide for ingress/egress.

1.02 REFERENCES

- A. ASTM A121–Zinc-Coated (Galvanized) Steel Barbed Wire.
- B. ASTM A392–Zinc-Coated Steel Chain-Link Fence Fabric.
- C. ASTM A428–Weight of Coating on Aluminum-Coated Iron or Steel Articles.
- D. ASTM A491–Aluminum-Coated Steel Chain Link Fence Fabric.
- E. ASTM A569–Steel, Carbon (0.15 Maximum Percent), Hot-Rolled Sheet and Strip Commercial Quality.
- F. ASTM A585–Aluminum Coated Steel Barbed Wire.
- G. ASTM F626–Fence Fittings.
- H. ASTM F567–Installation of Chain-Link Fence.
- I. ASTM F900–Industrial and Commercial Swing Gates.
- J. ASTM F1043–Strength and Protective Coatings on Metal Industrial Chain Link Fence Framework.
- K. Chain Link Fence Manufacturers’ Institute (CLFMI)–Product Manual.

PART 2–PRODUCTS

2.01 POSTS, RAILS, AND BRACES

- A. Construction:
 - 1. All posts and rails shall be either tubular pipe conforming to ASTM F1043 Group 1A, Schedule 40 with a Type A zinc coating, or Group 1C cold formed and welded pipe with a Type B zinc coating.

2. Post sizes shall be in accordance with the following:

LINE POSTS (Maximum 10 Feet Spacing)			
Height and Fence Type	Post Type	O.D. (IN.)	Weight (PLF)
6 feet or less	Group 1A	1.90	2.72
	Group 1C	1.90	2.38
Up to 8 feet	Group 1A	2.375	3.65
	Group 1C	2.375	3.12
Up to 10 feet with no wind screen or hardware cloth or privacy inserts	Group 1A	2.875	5.79
	Group 1C	2.875	4.64
Up to 10 feet with wind screen, hardware cloth or privacy inserts	Group 1A	4.0	9.10

CORNER AND BRACE POSTS			
Height and Fence Type	Post Type	O.D. (IN.)	Weight (PLF)
7 feet or less	Group 1A	2.375	3.65
	Group 1C	2.375	3.12
8 feet or 10 feet without wind screen, hardware cloth or privacy inserts	Group 1A	2.875	5.79
	Group 1C	2.875	4.64
10 feet with wind screen, hardware cloth or privacy inserts	Group 1A	4.0	9.10

3. Gate posts shall conform to manufacturer's specifications for various width gates. Minimum sizes shall be as follows:

GATE POSTS			
Leaf Width	Post Type	O.D. (IN.)	Weight (PLF)
6 feet or less	Group 1A	2.875	5.79
7 feet to 13 feet	Group 1A	4.0	9.10

4. Terminal posts shall be braced with the same material as top rail and trussed to line posts with 3/8-inch-diameter rods and tightened. One brace assembly shall be provided with each end or gate post and two assemblies with each corner or pull post.
5. Rails shall be 1 5/8 inches O.D., Group 1A 2.27 pound per foot or Group 1C 1.84 pounds per foot pipe.

- B. Line Posts: Line posts may be driven posts.

- C. Required Arms, Rails, and Tension Wires: Provide rampart arm, top rail, intermediate rail, and bottom rail as required.

2.02 FABRIC

A. Construction:

1. Fabric to be No. 9 gauge steel aluminum coated steel wire woven in a 2-inch mesh; top selvage to have knuckled finish, bottom selvage to be knuckled.
2. Fasteners:
 - a. Fasteners shall be galvanized steel wire clips and tie wires in accordance with ASTM A-641 Class III or aluminum coat in conformance with fence fabric specifications.
 - b. Provide fasteners for posts, top and intermediate rails, bottom rails, top tension wires, and braces of 9 gauge steel or 0.179-inch-diameter aluminum tie wires.
 - c. Provide fasteners for bottom tension wire of not smaller than 12 gauge or 0.149-inch-diameter aluminum tie wires.

2.03 GATES

A. General:

1. Provide additional horizontal and vertical members as necessary to assure proper gate operation and attachment to fabric and hardware.
2. Provide diagonal braces made of crossed adjustable length 3/8-inch-diameter truss rods on nonwelded gate frames and on welded frames where corner rigidity is not sufficient to prevent sag.
3. Gate frames shall be covered with the same fabric as the fence.
4. Weld or assemble gate frames with malleable or pressed steel fittings and rivets to provide rigid connections. Install fabric with stretcher bars at vertical edges. Attach to frame at 15 inches o.c. all sides. Provide caps for all gate frame work ends.

B. Gate Hardware:

1. Provide heavy-duty hinges of malleable iron, pressed or forged steel, non lift-off type, adjusted to permit 180° gate opening. Provide two hinges for each leaf.
2. Provide heavy-duty forked-type or plunger bar type latches for all single-leaf gates. Provide center stop and keeper for all double-leaf gates.

Provide spring latch for all sliding gates. Provide padlock eye as an integral part of all latches.

3. Provide heavy-duty track, ball bearing hanger sheaves framing and supports, guides, stays stops, and bracing necessary for sliding gates.

2.04 ACCESSORIES

A. General: All accessories, except tie wires and barbed wire, shall be galvanized to comply with ASTM F626.

B. Barbed Wire:

1. Provide three strands of barbed wire at top of fence.
2. Barbed wire shall be 2-strand, 12 1/2-gauge wire with 14-gauge, 4-point round barbs spaced approximately 5 inches o.c.
3. Finish shall be galvanized to meet ASTM A 121, Class 3 or aluminized to meet ASTM A 585, Class 2.

C. Barbed Wire Supporting Arms:

1. Arms shall be heavy pressed steel complete with provisions for anchorage to tubular end, corner, and pull posts attaching three rows of barbed wire to each arm.
2. Arms not required on roll formed terminal posts.
3. Single arms shall be integral with a post top weather cap.
4. Intermediate arms shall have hole for passage of top rail.
5. Arms shall be capable of withstanding, without failure, 250 pounds of downward pull at outermost end of arm.

D. Post Tops:

1. Material shall be pressed steel or malleable iron.
2. Top shall be weathertight.
3. Top shall permit passage of top rail.

E. Stretcher Bars:

1. Stretcher bars required for tubular end, corner, pull, or gate posts.
2. Bars shall be one-piece lengths equal to full height of fabric with minimum cross section of 3/16 inches by 3/4 inches.

3. Provide one stretcher bar for each gate and end post and two stretcher bars for each corner and pull post.
- F. Stretcher Bar Bands:
1. Material shall be heavy pressed steel.
 2. Spacing shall be 15 inches maximum o.c. to secure stretcher bar to tubular end, corner, pull, and gate post.
- G. Tension Wire: 7-gauge zinc-coated steel wire.

2.05 CONCRETE

- A. Concrete shall be Type A or A-FA as specified in Section 7–Cast-in-Place Concrete.

PART 3–EXECUTION

3.01 SITE WORK

- A. Prior to fence construction, remove and dispose of all trees, brush, logs, stumps, and other debris for a width of at least 12 inches each side of the proposed fence alignment.

3.02 CONCRETE FOOTINGS

- A. Excavate holes for footings to neat dimensions in firm ground to insure the post will be centered. Remove rock or other obstructions encountered to the required depth. Use forms in unstable soil, and allow them to remain in place for at least 24 hours after concrete is poured. Backfill, after forms are removed, with suitable material thoroughly compacted in place in layers to prevent settlement.
- B. The bottom of the post shall be 3 inches above the bottom of the hole. Gate posts larger than 4 inches o.d. shall have a base with a minimum diameter of 18 inches. Concrete bases shall be domed at the post and have a smooth troweled finish. Concrete footings shall cure for seven days before placing tension wires.

3.03 POSTS AND BRACES

- A. Set posts in a vertical position at the required location and alignment. Set tops at the required elevation to provide a smooth profile at the top rail or tension wire without abrupt changes and in conformity with the general contour.
- B. Place an end post at each end of each run of fence. Place a corner post whenever a break of 30° or more occurs in the horizontal alignment. Set an intersection post in line with an intersecting chain link fence and brace it to the adjacent posts of the intersecting fence.
- C. Place an intermediate braced post where the vertical alignment changes by more than 5°, or a change in fence grade of more than 9% occurs.

- D. Where driven posts are specified, all end, corner, gate, and brace posts must be set in concrete. Driven posts shall be driven a minimum of 32 inches into undisturbed soil.

3.04 POST BRACING ASSEMBLY

- A. Post bracing assemblies consist of one or more brace rails and a 3/8-inch truss rod as hereafter specified. Provide brace rails the same size as the top rail. Provide truss rods with an adjustable take-up adapter.
- B. Install a single bracing assembly at each gate and end post location.
- C. Install a double bracing assembly at each corner post and all intermediate braced posts.
- D. Provide the bracing assembly with one horizontal brace rail and one diagonal truss rod on all fences which have a top rail. Locate the horizontal brace rail in accordance with the manufacturer's specifications.
- E. Provide the bracing assembly with one horizontal brace rail and one diagonal brace rail and one diagonal truss rod on all fences which do not have a top rail. Locate the horizontal rail in accordance with the manufacturer's specifications.

3.05 STRETCHER BARS

- A. Provide one stretcher bar for each gate and end post and two for each corner and pull post, except roll form posts with integral loops. Attach to posts with heavy-duty pressed steel or malleable iron bands spaced at 15 inches o.c.

3.06 FABRIC

- A. Install, stretch, and anchor tension wires to each end, corner, gate, and brace post and properly attach to each line post before the fabric is placed. Pass top tension wire (when required) through the post top rail opening
- B. Attach the end of the fabric to the end, corner, gate, or brace posts (except roll form posts with integral loops) by means of a stretcher bar threaded through the end loops of the fabric and stretched to remove all slack with proper stretching equipment. Secure the stretched fabric to posts, rails, and tension wires with specified fabric fasteners. Install fabric fasteners on all posts at not greater than 14 inches o.c. and on rails and bottom tension wires at not more than 24 inches o.c. Where a top tension wire is installed, fasten to the fabric at not more than 18 inches o.c.
- C. Repeat stretching operations at approximately every 100 feet for each run of fence.
- D. Make splices in fabric by interweaving a wire picket through each end loop of each piece of fabric.

3.07 GRADE CLEARANCE

- A. For line and property fences, provide a clearance of 3 inches.

3.08 GATES

- A. Install gates plumb and level and adjust for smooth operation as intended without binding or hanging up.

3.09 BARBED WIRE

- A. Install barbed wire properly fastened to the rampart arms.

3.10 CLEANUP

- A. After chain link fence construction is completed, clean up all storage and work areas. Replace or repair, as required, all landscape features damaged or disturbed.

END OF SECTION

SECTION 13

RESIDENTIAL GRINDER PUMPING STATIONS

PART 1–GENERAL

1.01 SUMMARY

- A. Work Included: Provide factory-built grinder pump units consisting of a grinder pump core, and all necessary parts and equipment installed in fiberglass reinforced polyester tank.

1.02 QUALITY ASSURANCE

- A. Pumping station shall be in conformance with all applicable industry codes and laws.

1.03 DELIVERY, STORAGE, AND HANDLING

- A. The units shall be shipped to the job site factory assembled so that only the grinder pump need be installed in the basin and the alarm monitor need be installed in the home.

1.04 WARRANTY

- A. The pump manufacturer shall warrant the units being supplied against defects in workmanship and materials for a period of 5 years under normal use, operation, and service. The warranty shall be in printed form and apply to all similar units. Warranty shall include replacement parts and labor to replace same.

PART 2–PRODUCTS

2.01 MANUFACTURER

- A. The equipment specified shall be the product of any company experienced in the design and manufacture of grinder pumps for specific use in low pressure sewage systems. The company shall submit detailed installation and user instructions for its product; submit evidence of an established service support program including complete parts and service manual; and be responsible for maintaining a continuing inventory of grinder pump replacement parts.
- B. The pumps and basins shall be Environment-One, or equal.

2.02 GRINDER PUMP BASINS

A. GENERAL

- 1. All joints in the units shall be manufactured and factory tested for watertight integrity. All components of the unit such as cover, valves, floats, and piping shall be factory assembled. All materials exposed to

wastewater shall have inherent corrosion protection; i.e., cast iron, fiberglass, stainless steel, PVC, HDPE. Fiberglass tanks shall be constructed using isophthalic resins not orthophthalic resins.

B. SIMPLEX GRINDER PUMP TANK

1. The tank shall be molded of smooth fiberglass reinforced polyester resin. The tank shall have a nominal wall thickness of 3/16-inch. The tank shall be furnished with PVC closed flanges providing sockets to accept 6-inch nominal diameter PVC drain-waste-vent (DWV) pipe using the solvent-welded system. Sockets shall be located on the grinder pump basins based on the placement of the basin and the location of the houses being served. These socket fittings shall be securely fastened to the tank and shall be watertight.
2. The upper surface of the tank shall consist of a factory-sealed integral fiberglass reinforced polyester cover. This cover shall be made with the resin-rich (gel-coat) surface on the outside and shall also be stiffened by use of integrally molded reinforcing ribs capable of supporting the combined weight of the pump cores and a workman.

C. DUPLEX GRINDER PUMP TANK

1. The tank shall be molded of smooth fiberglass reinforced polyester resin. The tank shall have a nominal wall thickness of 3/16-inch. The tank shall be furnished with PVC closed flanges providing sockets to accept 6-inch nominal diameter PVC drain-waste-vent (DWV) pipe using the solvent-welded system. Sockets shall be located on the grinder pump basins based on the placement of the basin and the location of the houses being served. These socket fittings shall be securely fastened to the tank and shall be watertight.
2. The tank shall be fitted with an integral fiberglass baffle dividing it into two compartments which interconnect just below the elevation of the inlet fitting inverts. The upper surface of the tank shall consist of a factory-sealed integral fiberglass reinforced polyester cover. This cover shall be made with the resin-rich (gel-coat) surface on the outside and shall also be stiffened by use of integrally molded reinforcing ribs capable of supporting the combined weight of the pump cores and a workman.

D. ACCESSWAYS

Grinder pump units shall have accessways which shall comply with the following requirements:

1. The accessway shall be an integral extension of the tank described above, composed of smooth fiberglass reinforced polyester resin with minimum wall thickness of 3/16-inch. The accessway shall have an access opening at the top to accept a lockable domed fiberglass cover with skirt. The accessway shall include the following factory-supplied items: copper 1 1/4-inch grinder pump discharge extension(s) termination

in watertight bulkhead fitting(s) with external 1 1/4-inch main pipe thread. Provide core bolts, shutoff valve and quick-disconnect with compression coupling so that the pump core can be removed from grade using a hex wrench which shall be furnished with and stored in each outside unit. Internal wiring shall terminate in sealed junction boxes integral with accessway and suitable for outdoor use. All seals shall be factory tested to ensure their watertight integrity.

2. Accessway length shall be long enough to maintain minimum 6 1/2 feet of cover for outgoing pressure main as well as for incoming service. Accessways shall be tapered and ribbed at maximum 18-inch intervals to withstand earth loadings imposed.

2.03 GRINDER PUMP CORE

A. CORE UNIT

1. The grinder pump shall have a cartridge type easily removable core containing pump, motor, grinder, controls, check valve, anti-siphon valve, and wiring. The watertight integrity of the core unit, including wiring and access cover, shall be established by 100% factory air test at a minimum 5 psig. The core unit shall be mounted to the top of the tank and shall have two lifting eyes provided in the top housing which can be used to facilitate easy removal of the core unit from the tank.

B. Pump Unit:

1. The pump shall be an integral, vertical rotor, motor-driven, solids handling pump of the progressing cavity type with mechanical seal.
2. The rotor shall be through-hardened, highly polished, precipitation hardened stainless steel. The stator shall be composed of an ethylene propylene synthetic elastomer. All materials shall be suitable for domestic wastewater services.

C. MECHANICAL SEAL

1. The core shall be provided with a mechanical shaft seal to prevent leakage between motor and pump. The seal shall have a stationary ceramic seat and carbon rotation sealing surface with face precision lapped and held in position by a stainless steel spring.

D. GRINDER

1. The grinder shall be positioned immediately below the pumping elements and shall be direct-driven by a single, one-piece motor shaft. The grinder impeller assembly shall be securely fastened to the pump motor shaft. The grinder shall be of the rotating-type with a stationary hardened and ground-type chrome steel shredding ring spaced in accurate close annular alignment to the driven impeller assembly which shall carry two hardened Type 400 Series stainless steel cutter bars. This assembly shall

be dynamically balanced and operate without objectionable noise or vibration over the entire range of recommended operating pressures.

2. The grinder shall be constructed so as to eliminate clogging and jamming under all operating conditions including starting. Sufficient vortex action shall be created to scour tank free of deposits or sludge banks. These requirements shall be accomplished by the following items in conjunction with the grinder pump tank:
 - a. The grinder shall be positioned in such a way that solids are fed in an upflow direction.
 - b. The inlet shroud opening shall have a diameter no less than 5 inches.
 - c. At maximum flow, the average inlet velocity should not exceed 0.2 feet per second.
 - d. The cutter bars shall extend above the impeller disc 0.200 to 0.250 inches.
 - e. The impeller disc shall rotate at a nominal speed of 1,725 rpm.
 - f. The inlet shroud shall be 2 inches from bottom of tank within a tolerance of 1/4-inch.
3. The grinder shall be capable of reducing all components in normal domestic sewage, including a reasonable amount of "foreign objects" such as paper, wood, plastic, glass, and rubber to finely divide particles which will pass freely through the passages of the pump and the 1 1/4-inch-diameter discharge piping.

E. MOTOR

1. The motor shall be a minimum 1 hp, 110 or 230 volt, capacitor start, ball bearing, squirrel cage induction type with a low starting current not to exceed 30 or 60 amps.
2. Inherent protection against running overloads or locked rotor conditions for the pump motor shall be provided by the use of an automatic-reset, integral thermal overload protector incorporated into the motor. This motor protector combination shall be listed by Underwriters' Laboratories, Inc. for the application.

F. CHECK VALVE

1. The pump shall be equipped with factory installed, gravity-operated, flapper-type integral check valve built into the discharge pipe. This valve will provide a full-ported passageway when open and shall introduce a friction loss of less than 6 inches of water at maximum rated flow. Working parts will be made of a 300 Series stainless steel and fabricated

reinforced synthetic elastomer to ensure corrosion resistance, dimension stability, and fatigue strength. A nonmetallic hinge shall be an integral part of the flapper assembly providing maximum degrees of freedom for assured seating even at a very low back pressure. The valve body shall be a high gloss injection molded part made of PVC Type I-II.

G. ANTISIPHON FEATURE

1. The pump shall be constructed with a positive flooded suction configuration.
2. An added assurance that the pump cannot lose primer even under negative pressure conditions in the discharge piping system, the pump shall be equipped with an integral antisiphoning, air relief valve in the discharge piping just below the main check valve. This valve will automatically close when the pump is running and open to atmosphere when the pump is off.

H. CONTROLS

1. Necessary controls shall be integral with the grinder pump and shall be located in the top housing of the core unit inside a waterproof access cover. The cover shall be attached with stainless steel, tamper-proof fasteners.
2. Nonfouling wastewater level detection for controlling pump operation shall be accomplished by monitoring the pressure changes in an integral, air-bell level sensor connected through airtight tubing to a pressure switch. The level detection device shall consist of all static components in contact with the wastewater, or if floating elements are employed, they must have a clear space to float up into which extends a full 360° around the point of suspension or support.
3. Overflow sensing will be accomplished by a separate air-bell sensor of the same type.
4. To assure reliable operation of pressure-sensitive switches, each core shall be equipped with a quick-disconnect breather assembly, complete with check valve to prevent accidental entry of water into motor compartment in the event of flooding.
5. An alarm monitor with alarm light and buzzer, requiring 120 volts, suitable for remote installation, shall be furnished. This indicator shall be 6 by 6 by 4 inches of NEMA I construction. The red alarm light and 75 Db buzzer with push-button silencer shall be mounted on the front of the box. Alarm light shall remain on after button is pushed until cause of alarm is rectified.

I. REDUNDANT CHECK VALVE

1. Each grinder pump shall include in its package one separate check valve per core to ensure maximum protection against backflow in the event of sewer service line break.
2. The valve shall be 1 1/4-inch and of the gravity-operated, flapper-type. The check valve will provide a full-ported passageway when open and shall introduce a friction loss of less than 6 inches of water at maximum rated flow. Working parts will be made of a 300 Series stainless steel and fabric reinforced synthetic elastomer to insure corrosion resistance, dimension stability, and fatigue strength. A nonmetallic hinge shall be an integral part of the flapper assembly providing maximum degrees of freedom for assured seating at a very low back pressure.
3. The valve body shall be high gloss, injection molded PVC Type I-II with hub and socket compatible with 1 1/4-inch PVC solvent weld system.

J. LIFTING EYES

1. The grinder pump core unit shall have two lifting eyes provided in the top housing which can be used to facilitate easy removal of the core unit from the tank if necessary.

K. ELECTRICAL

1. The grinder pumps shall be free from electrical and fire hazards as required in a residential environment. As evidence of compliance with this requirement, the completely assembled and wired grinder pump in its tank shall be listed by Underwriters' Laboratories, Inc.
2. The grinder pumps shall meet accepted standards for plumbing equipment for use in or near residences, shall be free from noise, odor, or health hazards, and shall have been tested by an independent laboratory to certify its capability to perform as specified in either individual or low pressure sewer system applications. As evidence of compliance with this requirement, the grinder pump shall bear the National Sanitation Foundation seal of approval.
3. The grinder pumps shall meet the electrical requirements of NR 110.14(5)(b).
4. Where required, Contractor shall install a pedestal mounted 100 amps, 120/240 volts, single phase service for grinder pump stations.

L. OPERATION CONDITIONS

1. The pumps shall be of semipositive displacement-type. The pumps provided shall be capable of delivering 11 gpm against a normal rated total dynamic head of 92 feet. At zero head, the output shall be 15 gpm minimum. The pumps shall be capable of intermittent (5 minute minimum)

operation at any heads up to 150% of normal rated dynamic head while discharging at least 80% of rated flow without damage to the driving motor or piping system.

2.04 FACTORY TESTING

- A. Before shipment, the complete grinder pump station, including any required accessway or tube, shall be completely assembled at the manufacturer's plant, and shall be tested 100% for the following items prior to shipment: Flow rate at 35 and 92 feet of head, operation of normal and high level controls as specified levels, insulation resistance, power consumption in watts, current draw in amperes at nameplate voltage, noise level, and vibration within specifications.

PART 3-EXECUTION

3.01 INSTALLATION

- A. Excavation for the basin shall be to such a depth that the accessway cover is a maximum 4 inches above grade. The basin shall be installed on a minimum of 6 inches No. 8 stone aggregate.
- B. Groundwater shall be assumed to be at ground surface and Contractor shall provide concrete anchor to prevent floating of the unit. Concrete anchor shall be installed in accordance with manufacturer's directions. Backfill around the basin shall consist of clean sand to the ground surface. Contractor shall orient basin to allow connection of plumbing and if concrete anchor is required shall install anchor so as not to interfere with connection point. All vent piping shall be galvanized pipe. All nuts, bolts, and washers necessary for the installation of the vent piping to the grinder pump chamber shall be stainless steel. Connection to the grinder pump tank and all vent piping shall be watertight.

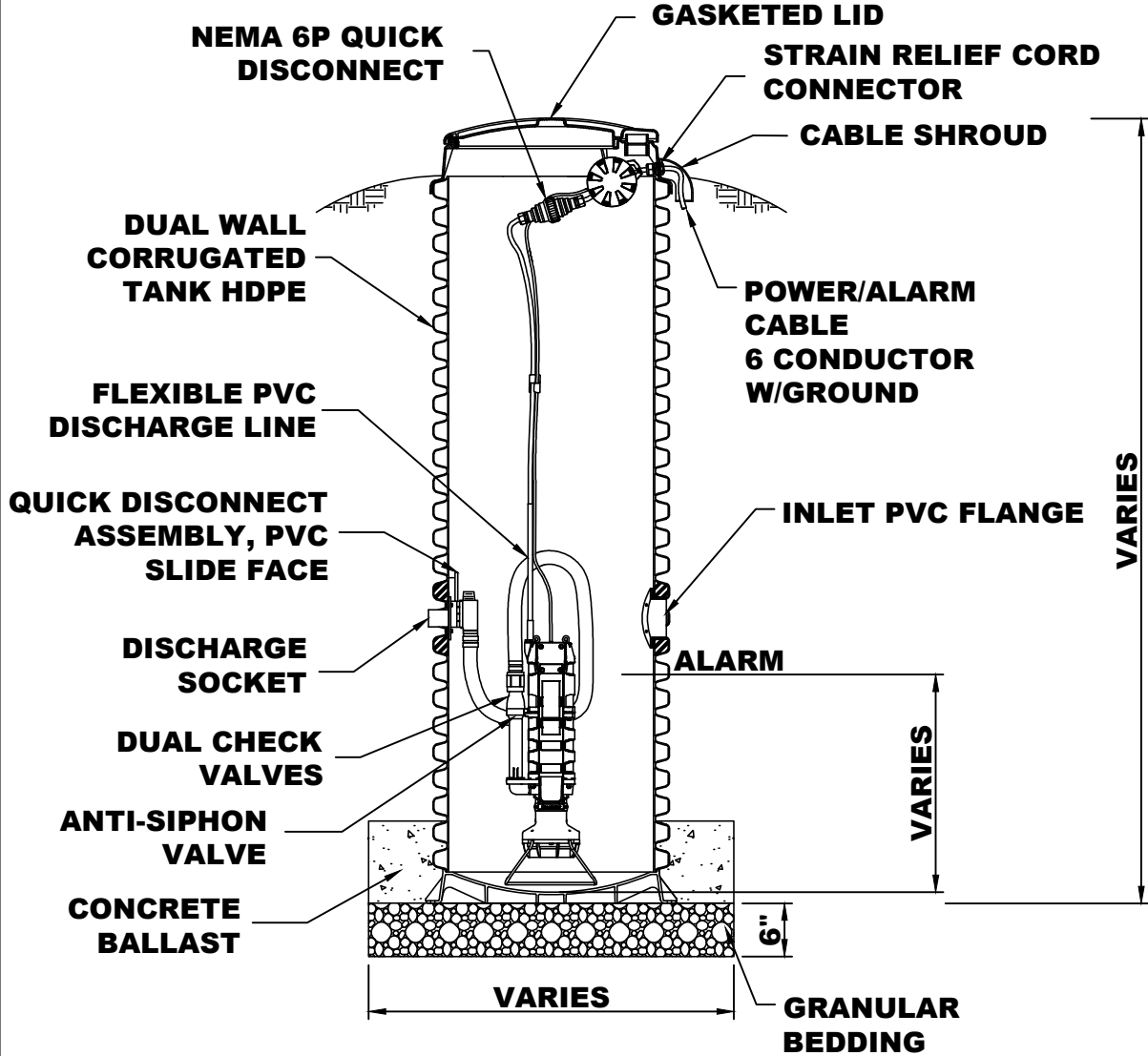
3.02 FIELD START UP AND TESTING

- A. Start Up and Testing: Each pump installation shall be started up and tested by the manufacturer's factory service technician. Procedure shall include:
 - 1. Verify that installation is according to manufacturer's recommendations.
 - 2. Fill with water to high water level.
 - 3. Verify alarm signal operation.
 - 4. Start and run pump.
 - 5. Verify amp draw and record.
 - 6. Verify proper operation and flow rate.

END OF SECTION

File: S:\COL\4100--4199\4122\067\Acad\Sanitary\Residential Grinder Pump Station.dwg Time: Feb 04, 2014 - 9:46am

NOTE:
PUMP STATION TO BE INSTALLED IN ACCORDANCE WITH MANUFACTURERS REQUIREMENTS.



RESIDENTIAL GRINDER PUMPING STATION

NO SCALE

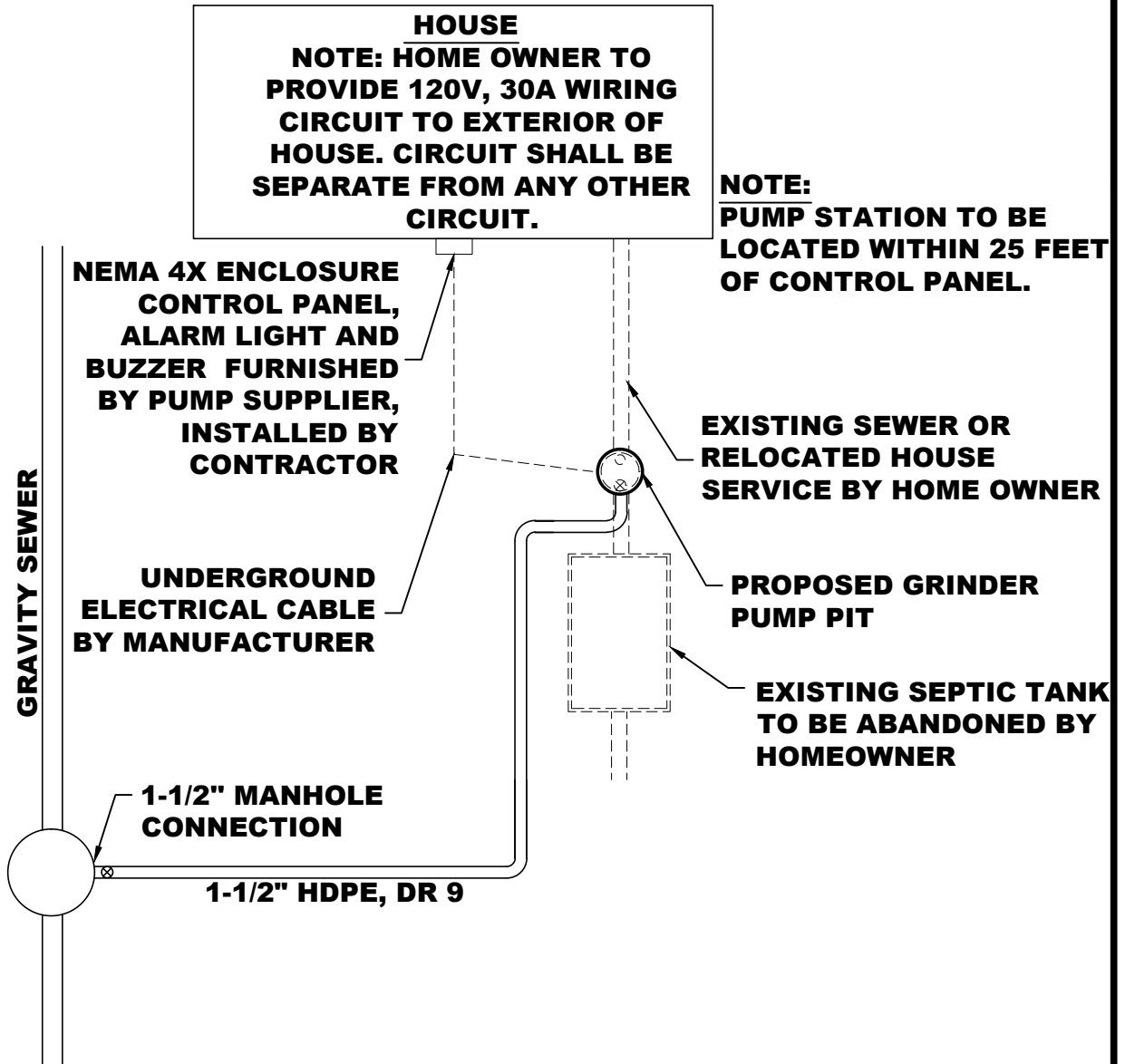
SECTION 13
RESIDENTIAL GRINDER PUMPS
STANDARD CONSTRUCTION SPECIFICATIONS
RESIDENTIAL GRINDER PUMP STATION
CITY OF SEYMOUR
SEYMOUR, INDIANA



FIGURE 13-1

4122.067

File: S:\COL\4100--4199\4122\067\Acad\Sanitary\Residential Grinder Pump Station.dwg Time: Feb 04, 2014 - 9:46am



TYPICAL RESIDENTIAL GRINDER PUMPING STATION PLAN

NO SCALE

**SECTION 13
RESIDENTIAL GRINDER PUMPS
STANDARD CONSTRUCTION SPECIFICATIONS
RESIDENTIAL GRINDER PUMP STATION PLAN
CITY OF SEYMOUR
SEYMOUR, INDIANA**



FIGURE 13-2

4122.067

SECTION 14
GREASE TRAPS

PART 1-GENERAL

1.01 SUMMARY

- A. Whenever the City determines that a grease trap is needed to protect the sewerage system or the operations of the WPCF from grease, oil, sand, or similar substances from occurring in a customer's sewage, then those traps shall be installed by the customer on his or her own lines at his or her own expense.
- B. All interceptors shall be of a type and capacity approved by the City, and shall be located as to be readily and easily accessible for maintenance, cleaning and inspection. Provided, however, that approval of any such grease traps by the City shall not relieve any person of the responsibility of complying with the discharge requirements of the City of Seymour.
- C. Where installed, all fats, grease, oil and sand traps shall be maintained by the owner, at his expense, in continuously efficient operation at all times.

PART 2-REQUIREMENTS

2.01 APPLICABILITY

- A. All users shall install grease traps designed to limit the introduction, contribution and discharge of greases into the City's wastewater collection system or WPCF. Grease traps with appropriate sampling or inspection points shall be installed at the user's expense whenever any user operates a commercial, industrial, or institutional cooking establishment.
- B. Grease, oil, and sand traps shall be provided by the user when, in the opinion of the City, they are necessary for the proper handling of wastewater containing excessive amounts of grease, oil, or sand; except that interceptors shall not be required for single-family residential users.
- C. It is recommended that solid food waste products be disposed of through normal solid waste/garbage disposal means. If a grinder/disposal is used it must be connected to the grease trap. The use of grinders is discouraged since it decreases the operational capacity of the grease trap and will require an increased pumping frequency to ensure continuous and effective operation.
- D. Commercial dishwashers must be connected to the grease trap. Dishwashers discharge soap and hot water which can melt grease and allow it to pass through undersized grease traps. Traps must be sized accordingly to allow enough detention time to allow water to cool and grease to solidify and float to the top of the trap.
- E. Grease traps and interceptors may also be required in other facilities, as deemed necessary by the City.

- F. The following types of establishments may be exempted from grease trap requirements:
 - 1. Private living quarters.
 - 2. Bars and clubs serving drinks only and where no food is Prepared.
 - 3. Grocery or convenience stores without food preparation, meat cutting or packaging, delicatessens or bakeries.
 - 4. Day care centers who primarily serve microwaved dishes, using single service items.
 - 5. Confectionery stores which sell, exclusively, unpackaged sweets, confections, nuts, ice cream, yogurt, and variety food items.
 - 6. Churches.
- G. Only floor drains which discharge or have the potential to discharge grease shall be connected to the grease trap.

PART 3-EXECUTION

3.01 GENERAL

- A. Grease traps shall be constructed in accordance with the City of Seymour standards and shall have a minimum of two compartments with fittings designed for grease retention. All grease removal devices or technologies shall be subject to the written approval of the City. Such approval shall be based on demonstrated removal efficiencies of the proposed technology.
- B. The minimum size of grease traps shall be determined according to the number of fixture units draining through the trap, but shall, in no case, have a total liquid capacity of less than one thousand (1000) gallons or exceed a capacity of 3,000 gallons. If the calculated capacity exceeds 3,000 gallons, multiple units plumbed in series shall be installed.
- C. Grease traps shall be equipped with double cleanouts on the outside of the trap in both the influent (prior to the trap) and effluent (after the trap) pipes.
- D. Grease trap shall be installed outside the building upstream from the sanitary sewer service lateral connection. A grease trap may not be installed inside any part of a building without written approval by the City.

3.02 CONSTRUCTION

- A. The total number of fixture units multiplied by one hundred and fifty (150) gallons shall determine the minimum total liquid capacity of the trap (minimum of 1000 gallons).

- B. The primary chamber shall occupy three-fourths (3/4) of the total liquid capacity of the trap.
- C. The dividing wall between each chamber shall completely divide the chambers (shall extend top to bottom) except where the specific design of the separator provides for underflow, in which case, the wall shall not be greater than twelve (12) inches from the bottom, between the chambers rather than the flow traveling through a pipe.
- D. Fats, grease, oil and sand traps shall be constructed of impervious materials capable of withstanding abrupt and extreme changes in temperature. They shall be of substantial construction, watertight and equipped with easily removable covers which, when bolted in place, shall be gastight and watertight.
- E. The influent shall enter each chamber below the static water level in accordance with the specifications outlined in this paragraph. The effluent shall discharge from below the static water level of the chamber in accordance with the specifications outlined in this paragraph.
 - 1. The influent line into all chambers shall terminate no greater than eighteen (18) inches from the bottom of the chamber.
 - 2. The effluent from all chambers shall discharge from the lower twelve (12) inches of the chamber.
 - 3. There shall be no openings in any influent or effluent pipe that will allow liquid to enter or exit the chamber at any point other than the intake or discharge point of the pipe.
 - 4. The static water level shall be maintained throughout the entire trap.

3.03 ACCESS

- A. Access to grease traps shall be available at all times, to allow for their maintenance and inspection. Access to trap shall be provided by two manholes (one on each compartment) terminating at finished grade with cast iron frame and cover.
- B. Entry into each chamber of the grease trap shall be accessible.
- C. The minimum requirement for the sampling point shall be a four inch vertical clean-out.

PART 4-MAINTENANCE

4.01 CLEANING

- A. The user, at the user's expense, shall maintain all grease traps to assure proper operation and efficiency. Maintenance of grease trap shall include the complete removal of all contents, including floating materials, wastewater, and bottom

sludge and solids. This work shall be performed by a qualified and licensed hauler. Decanting or discharging of removed waste back into the trap from which it was removed or any other grease trap, for the purpose of reducing the volume to be disposed, is prohibited. This service shall also include a thorough inspection of the trap and its components. Any needed repairs shall be noted. Repairs shall be made at user's expense.

- B. Materials removed from traps shall be utilized by industry, recycled, or disposed at a facility designated by or acceptable to the generator where the owner or operator agrees to receive the wastes and the disposal facility has documentation showing the facility meets all requirements of the State. All wastes shall be disposed in a suitable manner in accordance with applicable Federal, State, and Local laws.
- C. The grease trap must be pumped out completely a minimum of once every month, or more frequently, as determined by the City, as needed to prevent carry over of grease into the sanitary sewer system.

4.02 MAINTENANCE LOG

- A. A grease trap cleaning/maintenance log indicating each pumping for the previous 24 months shall be maintained by each owner. This log shall include the date, time, amount pumped, hauler, disposal site, and any repairs made to the system. It shall be kept in a conspicuous location for inspection. Said log shall be made available to the City upon request.

PART 5-ADDITIVES

5.01 BIOLOGICAL

- A. Any biological additive(s) placed into the grease trap or building discharge line including, but not limited to, enzymes, commercially available bacteria, or other additives designed to absorb, purge, consume, treat, or otherwise eliminate fats, oils, and grease shall require written approval by the City prior to use. The use of such additives shall in no way be considered as a substitution to the maintenance procedures required herein.

5.02 INORGANIC

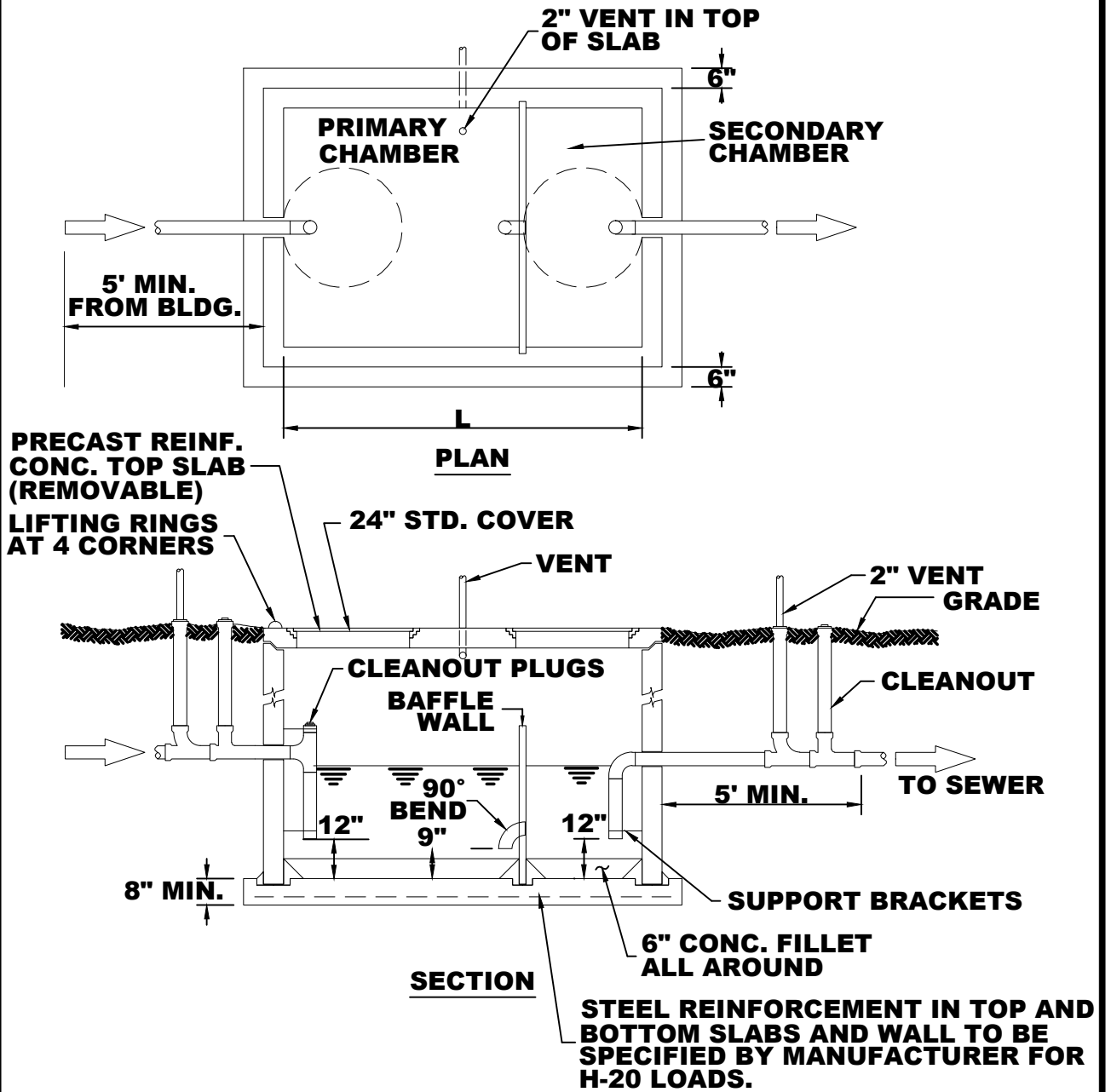
- A. Users are required to keep the grease trap or interceptor free of inorganic solids such as grit, towels, gloves, cigarettes, eating utensils, etc., which could clog or settle in the trap, thereby reducing the effective volume or capacity of the trap.

5.03 CHEMICAL TREATMENT

- A. Chemical treatments such as drain cleaners, acid, or other chemical solvents designed to dissolve or remove grease shall not be allowed to enter the grease trap.

END OF SECTION

File: S:\COL\4100--4199\4122\067\Acad\Grease Trap.dwg Time: Feb 04, 2014 - 9:46am



TYPICAL GREASE TRAP
NO SCALE

SECTION 14
GREASE TRAPS
STANDARD CONSTRUCTION SPECIFICATIONS
GREASE TRAP DETAIL
CITY OF SEYMOUR
SEYMOUR, INDIANA



FIGURE 14-1

4122.067

SECTION 15

AS-BUILT/RECORD DRAWINGS

PART 1-GENERAL

1.01 SUMMARY

- A. The Contractor will be responsible for preparation and submittal of digital as-builts/record drawings as required by the following requirements.
- B. Files must be saved and submitted on a CD-ROM in a jewel case without using file compression.
- C. Files must be submitted in both DWG and PDF format.
- D. The CD label shall include the following:
 - 1. Company name with prepared by statement.
 - 2. Project name.
 - 3. Date that data is burnt onto CD.
- E. File names should make sense to a viewer who may not be familiar with the project and be indicative of the contents of the file.
- F. All pertinent drawing elements will reside in the primary drawing file. There shall be no cells, nodes, blocks, or reference files (x-refs) attached to the drawing.
- G. Separate layers for structures, pipes, easements, annotation etc. with a logical description for each layer.
- H. Projection shall be referenced to NAD83, Indiana State Plane Coordinate System, East Zone, using U.S. Survey Feet. Elevations shall be in the NAVD 88 vertical datum. The coordinate location of the items listed below shall be obtained by a field survey and with vertical data that meets survey grade accuracy.
- I. Tie into section corners in the Indiana State Plane Coordinate System to ensure proper orientation.
- J. **All easements shall be represented.**
- K. Drawings must have graphical representation of all off-site platted easements, right-of-ways, lot lines, etc. encompassing infrastructure improvements.
- L. The digital file must show the exact as-built location of the following items:
 - 1. Storm water manholes, inlets, end sections, risers, and pipes.

2. Detention-retention ponds with normal pool elevation and top of bank drawn as closed polylines.
 3. Any sub-surface drains including field tiles.
 4. Flow line of swales and ditches with a bottom width of 1 foot or greater.
 5. Sanitary sewer manholes, sewer mains, pumping stations, force mains, wyes, valves and laterals.
 6. Utility markers.
 7. End of stubs.
 8. Pipe casing including location of ends of casing.
 9. Other utilities including water mains and services connections, hydrants and valves, gas mains, electrical, cable and telephone.
- M. All storm and sanitary structures will have top of castings and invert elevations.
- N. All pipes will have a length, pipe size (in inches) and material listed.
- O. Contractor shall submit two full size (22" x 34" or 24" x 36") paper copies of the as-built/record drawings to the City. Drawings must be legible, to scale, contain all as-built data including the profile sheets, and be reproducible to scale.

END OF SECTION